



BMRX-200 DC Rotary Level Indicator

Operating Instructions
Please Read Carefully

BinMaster: Division of Garner Industries LLC
Lincoln, NE
402-434-9102

info@binmaster.com | www.binmaster.com

TABLE OF CONTENTS

GENERAL SPECIFICATIONS.....	3
SAFETY SUMMARY	4
1.0 INTRODUCTION	5
2.0 INSTALLATION.....	5
2.1 Mounting Summary.....	5
2.2 Location and Mounting	7
2.3 Input Power and Field Wiring	9
2.4 Grounding	10
3.0 DPDT RELAY.....	10
3.1 Fail Safe High	10
3.2 Fail Safe Low	10
4.0 WARRANTY AND CUSTOMER SERVICE.....	11
4.1 Limited Warranty	11
4.2 Customer Service	11
5.0 DISPOSAL.....	11

SPECIFICATIONS

BMRX-200 DC GENERAL SPECIFICATIONS

Power Supply:	12 to 24 VDC
Supply Tolerance:	-15% to +10%
Load:	4 VA
External Over Current Protection	10A max.
Ambient Temperature: (Electronics)	-40°F to +131°F (-40°C to +55°C)
Process Temperature:	400°F (204°C)
Enclosure Type:	4X / IP66
Enclosure Material:	Die cast aluminum, powder coat finish
DPDT Relay Output:	10 Amps 250 VAC
Fail Safe:	Switch selectable "High" or "Low" level modes
Mounting:	1-1/4" NPT, 1-1/2" NPT, 1-1/2" Tri-clover
Approvals:	Hazardous Location Rating C/US Class II Div I Groups E, F & G
Standards:	ATEX  II 1 D Ex ta h IIIC T135°C Da IECEx Ex ta IIIC T135°C Da Ex h IIIC T135°C Da

Standards:	UL 1203:2013ED.5+R:16Feb2018 CSA C22.2#25:2017Ed.4 UL 61010-1:2012 CSA C22.2#61010-1-12:2012
------------	---



Intertek
5003113

Conforms to UL STD 1203
Certified to CSA STD C22.2 #25

Conduit Entries:	3/4" NPT
------------------	----------



Shaft Seal:



1/2 micron, 30 PSI NOTE: The fluorocarbon seal is extremely durable an typical lifespan in normal operation is 8 to 10 years, but should be inspected every three years for wear and replaced as necessary. Output shaft bearings are NOT field replaceable. If damaged, the instrument should be re placed or repaired by the manufacturer. See Customer Service section for factory contact.

SAFETY

SAFETY SUMMARY

Review the safety precautions to avoid injury and prevent damage to equipment. The product should be installed, commissioned, and maintained by qualified, authorized personnel only. If installed per installation manual, routine maintenance is not required.

Install according to instructions. Field wiring should conform to all national and local electrical codes and any other agency or authority having jurisdiction over the installation. For installations in Class I Hazardous locations the installation shall comply to Article 501 of the National Electrical Code. Conditions of Safe use instructions shall be followed as per the IECEx or ATEX certificates.

Use electrical wire that is sized and rated for the maximum voltage and current of the application. The internal grounding terminal shall be used as the equipment grounding means, and that the external terminal is only a supplemental bonding connection where local authorities permit or require such a connection. For EPL Da ta installations, supply fault current must be 1.5kA maximum.

Observe terminal and relay contact ratings on the nameplate and in the installation manual.

Ensure the enclosure cover is in place and secured tightly during normal operation. In potentially wet environments, thoroughly seal all conduit entries.

If this product is used in a manner not specified by the manufacturer safety protection could be compromised.

If dissimilar metals are used to mount the level control, the enclosure should be inspected for galvanic action every three years.

All sealing devices including cable glands, blanking elements, thread adapters and stopping plugs are required to be certified to type of protection Ex db or Ex ta as applicable, be suitable for use in an ambient temperature range of -40°C to +85°C, be suitable for use in Group IIB and be suitably sized for the cabling which is carried. Installation shall take into account any applicable special conditions for safe use and all relevant installation requirements of IEC 60079-14. No more than one thread adapter may be used on any entry and a thread adapter may not be used in conjunction with a blanking plug.

Safety Terms and Symbols



WARNING: Do not open enclosure when an explosive atmosphere is present



WARNING: Potential electrostatic charging hazard – see instructions



WARNING: Equipment flame paths (mounting coupler / output shaft) must not be repaired or modified



WARNING: Warning statements identify conditions or practices that could result in injury or loss of life. Risk of electrical shock.



CAUTION: Caution statements identify conditions or practices that could result in damage to this product or other property.

INTRODUCTION

1.0 INTRODUCTION

The BinMaster BMRX-200 DC is a rotary level sensor that provides reliable point level detection in bulk solids, including powder, pellet, and granular materials.

The BMRX-200 DC motor rotates the drive shaft and paddle at 1 RPM. When the material fills to the level of the indicator paddle, it causes the paddle to stop rotating indicating a covered condition. When the material falls away, the paddle resumes rotating to indicate an uncovered condition.

Nameplate Label

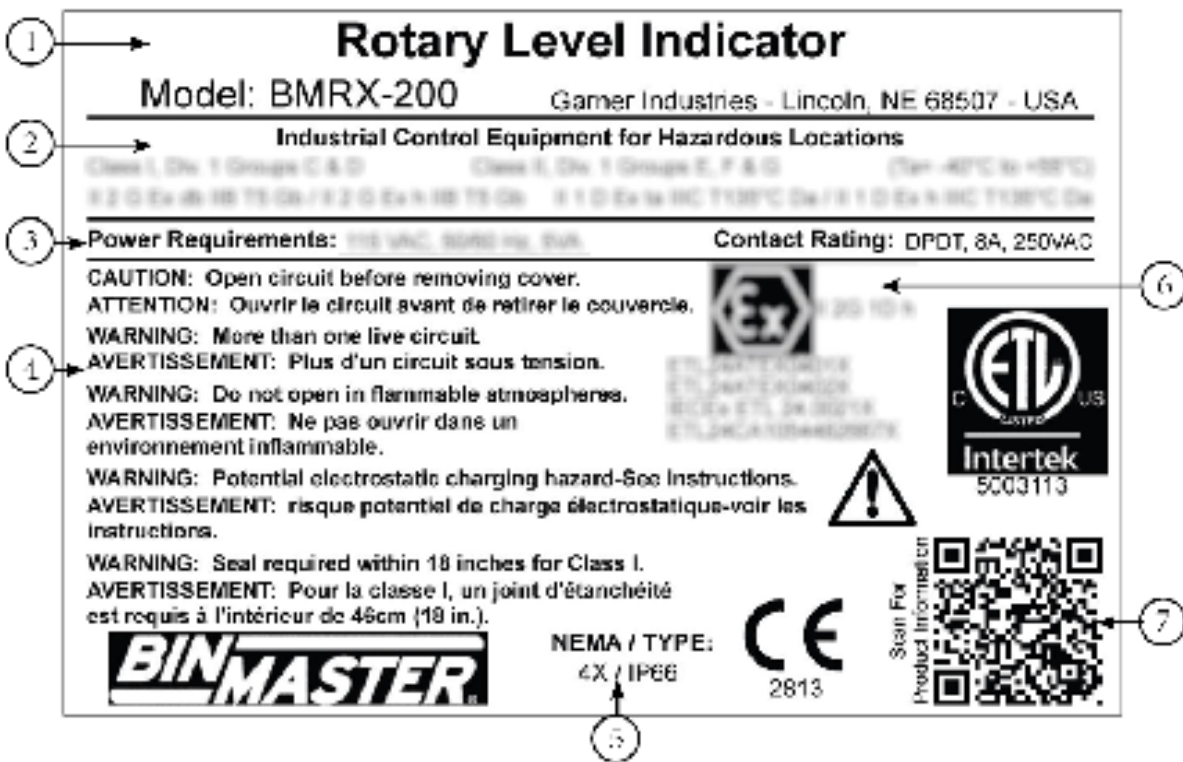

1. Product Type
2. Approvals
3. Power and signal ratings
4. Cautions and warnings
5. Protection rating
6. Approval markings and certificates
7. QR code for product information

2.0 INSTALLATION

2.1 Mounting Summary

The BMRX-200 DC has three optional process fittings available to mount the indicator; 1.25" NPT, 1.5" NPT, or 1.5" tri-clover fitting. The BMRX-200 DC can be mounted using a mounting plate, welded in couplings, or mating the tri-clover fitting with a flanged end with an internal diameter big enough for the paddle to fit through.

Mounting Plates

Mounting plates allow installing a completely assembled rotary through the vessel side or top. The mounting plates have 6 bolt holes equally spaced on a 7-inch bolt circle. Mounting plates are available with 1.25" or 1.5" NPT half or full couplings dependent on the process fitting size of the rotary.

Half couplings are used for all side mount installations or if top mounting a rotary without using a guard pipe.

Full couplings are for top-of-vessel installations when using shaft extensions and shaft guard pipes. Do NOT use full couplings for side mounting. The void on the process side of a full coupling could allow material to pack in the void and interfere with rotation of the rotary shaft.

Cut a hole in the vessel wall large enough for the paddle to fit through. Place the gasket between the mounting plate and the vessel and install 6 mounting bolts through the mounting holes to secure the plate to the vessel.

Mounting without Mounting Plates

Select a coupling or tri-clover fitting that matches the size of the process fitting on the rotary. Cut a hole in the vessel big enough to fit the coupling through the vessel wall. Weld the coupling to the vessel well to seal out moisture and dust.

Mounting Plates

Mounting plates are needed when a completely assembled rotary is mounted on the bin wall from the outside. Cut a 5-1/2" hole in the bin. Drill six bolt holes around the hole to match the mounting plate. Bolt the plate, with the unit attached, into place. Mounting plates are available in carbon or stainless steel

Full Coupling

For use with all rotary level controls. Full coupling is used for top-of-bin installations where shaft extensions and shaft guards are used.

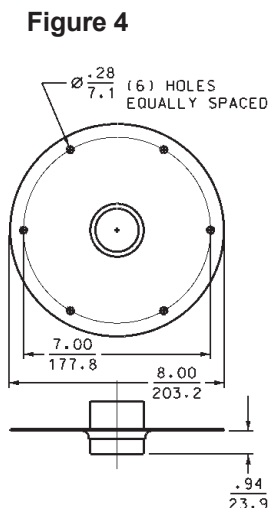

Half Coupling

For use with all rotary level controls. Half coupling is used primarily for side of bin installations.

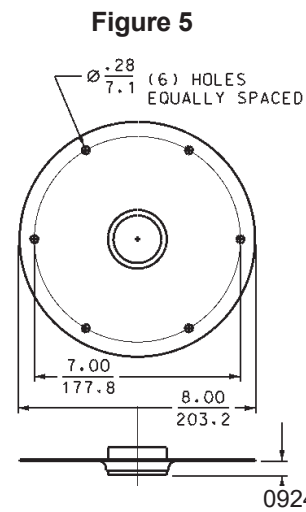

2.2 Locating and Mounting

SIDE MOUNT

1. Determine location and cut hole inside of bin to fit outside diameter of 1-1/4" pipe coupling (1.950").
2. Weld on half of standard 1-1/4" pipe coupling to bin wall flush with inside of bin.
3. Insert hub into coupling and turn rotary so conduit entries are pointed down toward the ground.
4. Screw paddle into place and replace lock pin.
5. Shaft and paddle should be shielded in low level mounting to protect from material flow.
6. For side mounting, a solid coupler is recommended.

Figure 1

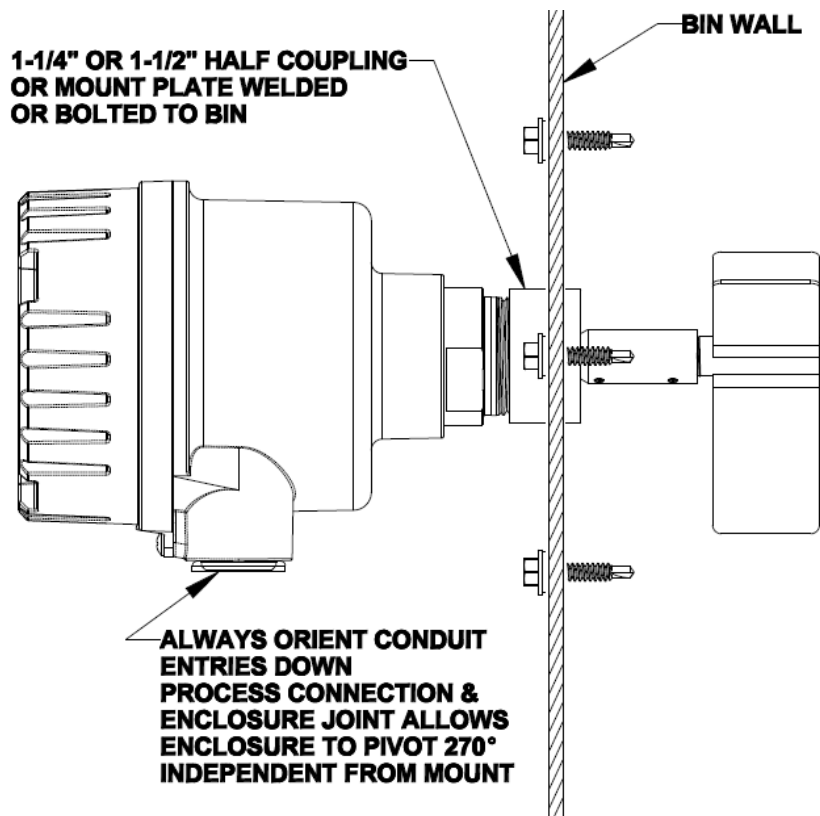

TOP MOUNT

1. Determine mounting location and cut a hole in top of bin to fit outside diameter of 1-1/4" pipe coupling (1.950").
2. Position coupling halfway into bin and weld to bin.
3. Turn rotary so conduit openings are in desired location.
4. Add 1/4" extension pipe of desired length with standard 1/4" coupling on bottom end.
5. Cut 1-1/4" support pipe approximately 4" shorter than overall length of 1/4" pipe shaft if used with flexible coupling.
6. Insert 1-1/4" pipe into coupling and tighten.
7. Insert paddle into 1/4" coupling and drill holes for lock pins.

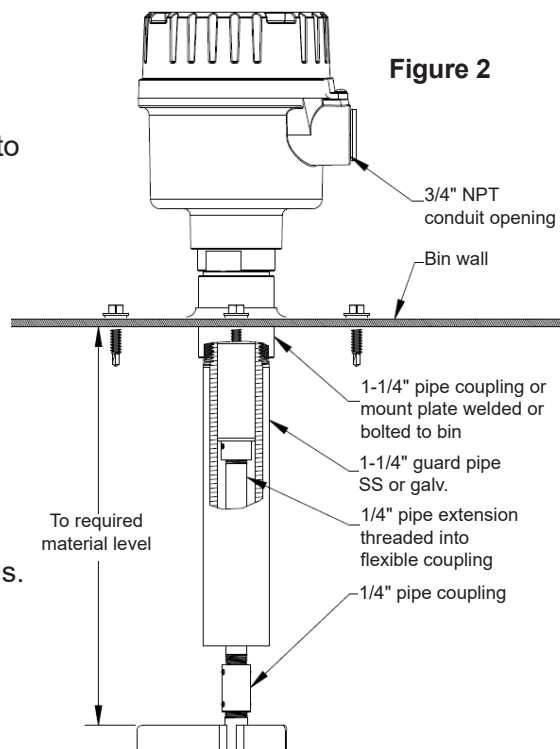
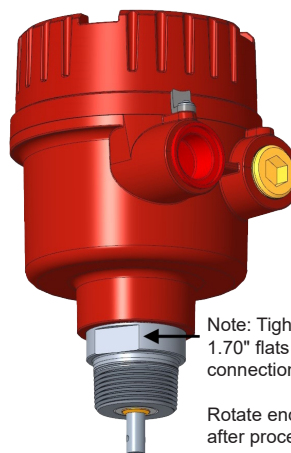

Figure 2

MOUNTING

Use the 1.70" flats provided on the process connection for tightening the instrument into the mounting coupler or mounting plate.

The enclosure can be rotated 360 degrees after the process connection is tight. **NOTE:** For side mount application, rotate enclosure conduit entries **DOWN** after the process connection is tight.



NOTE:
3/4" NPT conduit entries. Torque electrical fittings to 5 ft lbs minimum

Note: Tighten/loosen only using the 1.70" flats provided on the process connection.

Rotate enclosure conduit entries down after process connection is tight.

Mounting Orientation

To prevent moisture or humidity from entering the unit when mounted on the side of the bin, the rotary **MUST** be mounted with the conduit entries facing down.

Conduit Seal

When installing the rotary in environments where moisture or moist air may enter the unit through the electrical conduit, the conduit openings should be sealed with an appropriate duct seal compound or putty.

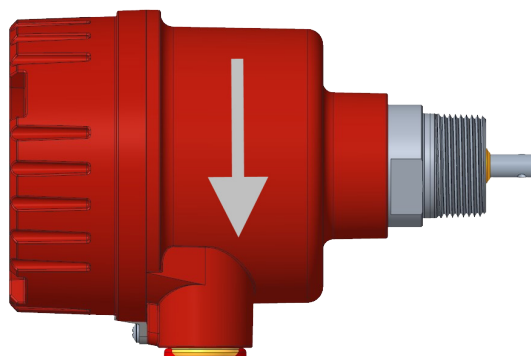

NOTE: Conduit entries must be fitted with a suitable sealing device for the Hazardous Location. All unused conduit entries must be sealed and if any conduit entry blanking plugs are removed or replaced, they must be fitted with a suitable certified sealing device.

2.3 Input Power and Field Wiring

The BMRX-200 DC is powered by 12 to 24 VDC (-15% to +10%)
 Field wiring should conform to all national and local electrical codes and codes of any other agency or authority with jurisdiction over the installation. For power input, use wire sized and rated for the maximum voltage and current according to equipment ratings with a temperature rating of at least 70°C. For SPDT switch output, use wire sized and rated for the maximum voltage and current for the application, up to 250 VAC 10A, and has a temperature rating of at least 70°C. Installation must be done by qualified personnel.
 NOTE: Open the screw terminals fully before inserting wiring.

BMRX-200 DC Wiring Input Power

Power input to the BMRX-200 DC is connected to the POWER terminals labeled L and N.

DC Models

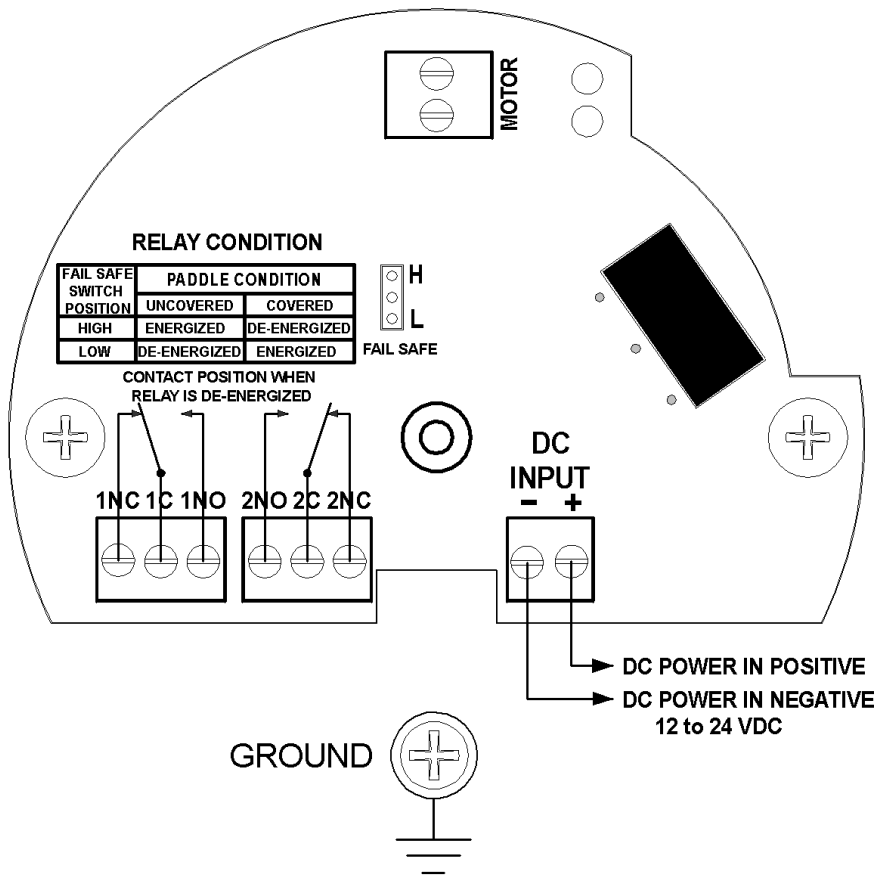



2.4 Grounding

An equipment grounding connection (earth ground) to the rotary is required for safety. Connect the ground conductor to the green grounding screw inside the enclosure. An external equipotential bonding connection where local authorities permit or require such a connection.

3.0 DPDT Relay

The DPDT relay utilizes a Fail Safe selector switch. There are two positions for the switch, High (H) and Low (L). A Fail Safe condition means the DPDT relay contact positions are set so in the event of a power failure the relay will be de-energized and the contacts will indicate a condition that is deemed safe for the application.

3.1 Fail Safe High

Fail Safe High means that the relay will be energized when the paddle is rotating (uncovered) and will de-energize when the paddle is covered. In this mode, a power failure will cause the relay contacts to indicate that the paddle is covered, whether it is or not.

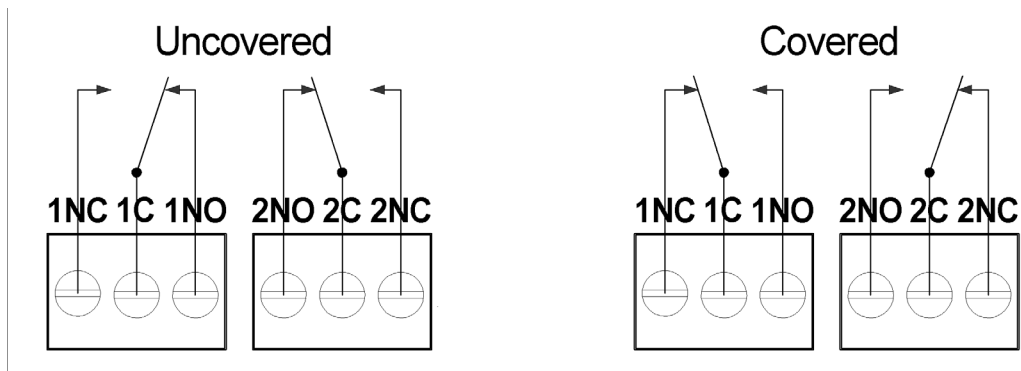

3.2 Fail Safe Low

Fail Safe Low means that the relay will be de-energized when the paddle is rotating (uncovered) and will energize when the probe is covered. In this mode, a power failure will cause the relay contacts to indicate that the paddle is uncovered, whether it is or not.

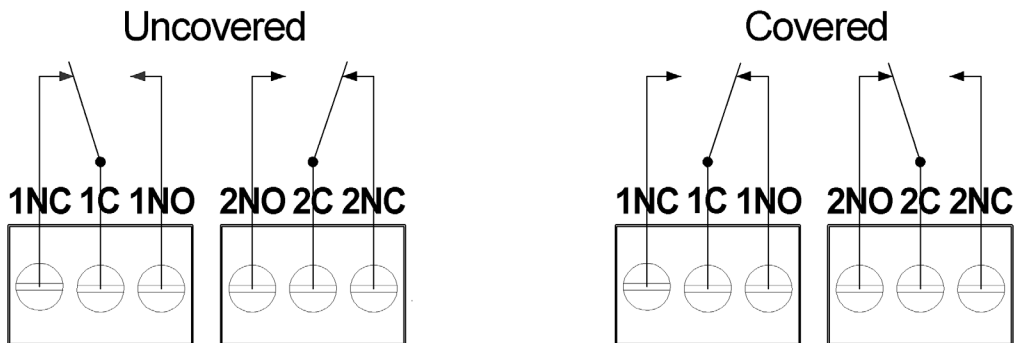

4.0 WARRANTY AND CUSTOMER SERVICE

4.1 Limited Warranty

LIMITED PRODUCT WARRANTY. Products manufactured by Seller are warranted for a period of one (1) year from date of shipment against defective materials and workmanship (the "Warranty Period"). SELLER MAKES NO OTHER WARRANTY, EXPRESS OR IMPLIED, AND ANY WARRANTY OF MERCHANTABILITY OR FITNESS FOR A PARTICULAR PURPOSE IS HEREBY DISCLAIMED AND EXCLUDED.

This limited warranty does not extend to labor charges or other costs related to the removal and/or replacement of defective products or services. Any technical advice or services furnished by Seller with respect to the products is given without charge, and Seller assumes no obligation or liability for the advice given or results obtained, all such advice being given and accepted at Buyer's sole risk and expense. If the products are being acquired for resale, Buyer will make, in connection with any such resale, only those warranties contained herein and will indemnify Seller and its officers, directors, agents, employees, affiliates, successors, and assigns against any claims, causes of actions and judgments which arise from any representations, warranties, or agreements made by or entered into by Buyer, other than those contained herein.

WARRANTY EXCLUSIONS. Notwithstanding Seller's Limited Product Warranty, products that have been or are (1) damaged by accident, corrosion, the elements, abuse, misuse, misapplication, vandalism, negligence, improper transportation, handling, storage, use or lack of proper and reasonable maintenance, (2) repaired or altered by anyone other than Seller or its authorized service providers, (3) modified or altered without Seller's written authorization, or (4) specially manufactured by Seller as per specifications provided by Buyer, are expressly excluded from Seller's Limited Product Warranty.

4.2 Customer Service

BinMaster's toll-free Customer Service phone number is 1-800-278-4241. Call the Technical Service Department for support Monday through Friday from 8:00 AM to 5:00 PM Central Time. International customers call 1-402-434-9102 or techsupport@binmaster.com.

5.0 DISPOSAL

This product contains recyclable materials and electronics that can be easily separated and recycled by specialized recycling companies. Consult local authorities for proper disposal locations.

EU / IEC Declaration of Conformity

Manufacturer:

Garner Industries LLC. dba BinMaster Level Controls
2021 Transformation Drive Suite 2230
Lincoln, NE 68508 USA
Phone: 402-434-9100

Garner Industries LLC declares under our sole responsibility that all models of the BMRX level control devices listed below comply with the following directives and harmonized standards. This product if installed, operated and maintained as described in this manual will provide a safe and reliable level control for bulk solid materials.

Product: BMRX-X00 Level Control

Models: BMRX-200

Manufacturing Location:

Garner Industries LLC. dba BinMaster
3435 Schworer Drive
Lincoln, NE 68504
USA

ATEX Directive 2014/34/EU

ATEX Classification
IECEX



II 1 D Ex ta h IIIC T135°C Da (Ta = -40°C to +55°C)
Ex ta IIIC T135°C Da Ex h IIIC T135°C Da

Examination certificates:

ETL24ATEX0401X
IECEX ETL 24.0021X

Harmonized standards:

IEC 60079-0:2017 Ed.7
IEC 60079-31:2022 Ed.3
ISO 80079-36:2016 Ed.1
ISO/IEC 80079-37:2016
IEC 61010-1:2010 Ed.3+C1;C2

Notified Body:

Intertek 0359

All test reports and documentation are held and can be obtained from Garner Industries LLC dba BinMaster.

Location: Lincoln, Nebraska, USA

Doug Hartzell
Senior Design Engineer
8/15/2024

BinMaster: Division of Garner Industries LLC
Lincoln, NE
402-434-9102

info@binmaster.com | www.binmaster.com