

This drawing is the property of Gamer Industries. It is issued in confidence on the condition that it is to be returned on request and that it is not to be copied or reproduced in any way, or used in the manufacture of the subject matter thereof without the written consent of Gamer Industries.

DIMENSIONS ARE IN INCHES UNLESS NOTED OTHERWISE



Division of Gamer Industries / 7201 North 98th Street / Lincoln, NE 68507  
 (402) 434-9102 / fax (402) 434-9144 \ www.binmaster.com

**ASSEMBLY ALSO INCLUDES (NOT SHOWN):**

PART No.	DESCRIPTION
110-0048	SCREW, HEX HEAD 1/4-20 X 3/4 SS
140-0023	NUT, HEX KEPS 1/4-20 SS
145-1010	WASHER LOCK INTERNAL TOOTH 1/4 SS
165-0011	SLEEVE PLATED 1/16 BRASS
165-0026	STOP, SLEEVE ROUND ZINC COPPER
212-0042	CAP, SUREDROP, ACETAL
299-0584	THIMBLE CABLE 1/16 SS
299-0696	ROD, THREADED, SBR FLOAT
299-0799	BALL STOP FOR SUREDROP ACETAL

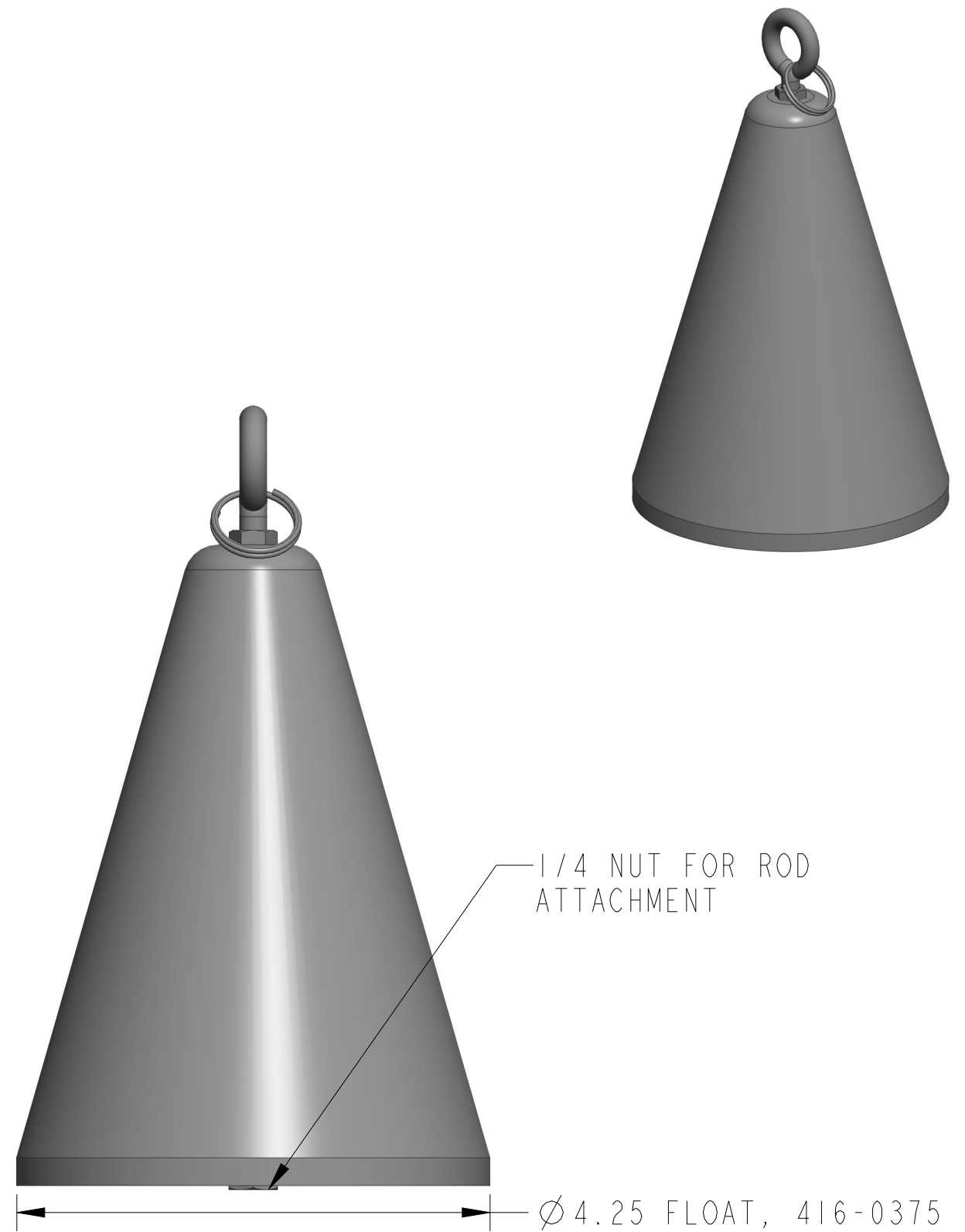
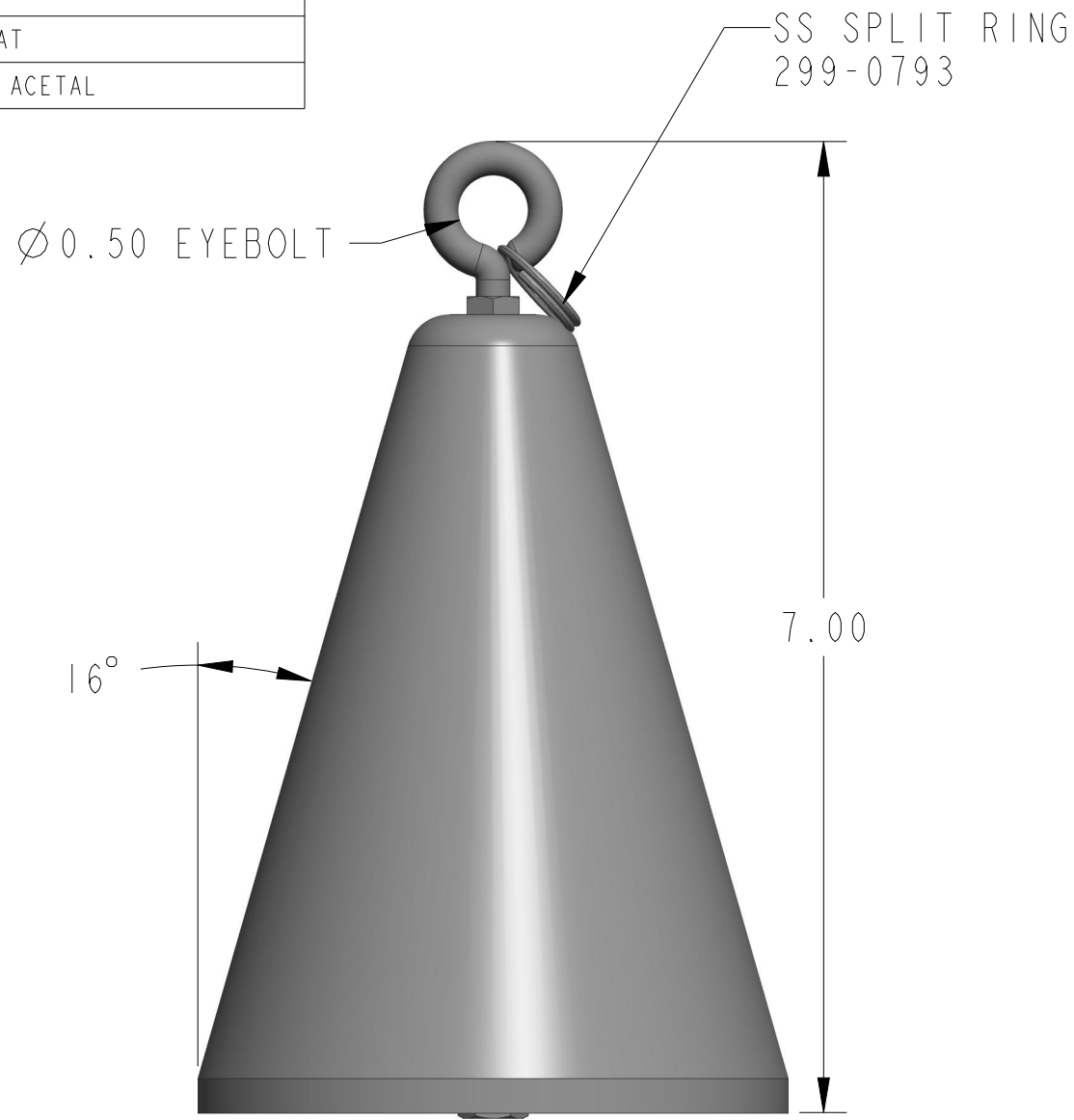

SCALE 0.750

**TITLE:** MTG DIM, CONE, 4.00, B3

**Model No.:** B3

**P/N:** 416-0375

**DWG No.:** 418-0071

**MATERIAL:** 316 SS

REVISION  
A

PAGE  
1 OF 1