



BMRX-300

Rotary Level Indicator

Operating Instructions
Please Read Carefully

BinMaster: Division of Garner Industries LLC
Lincoln, NE
402-434-9102

info@binmaster.com | www.binmaster.com

TABLE OF CONTENTS

GENERAL SPECIFICATIONS.....	3
SAFETY SUMMARY	4
1.0 INTRODUCTION	5
2.0 INSTALLATION.....	5
2.1 Mounting Summary.....	5
2.2 Location and Mounting	7
2.3 Input Power and Field Wiring	9
2.4 Grounding	10
3.0 DPDT RELAY.....	10
3.1 Fail Safe High	10
3.2 Fail Safe Low	10
3.3 Status LED.....	11
3.4 Status Relay.....	11
3.5 Time Delay	11
3.6 Changing the Time Delay	12
4.0 WARRANTY AND CUSTOMER SERVICE.....	13
4.1 Limited Warranty.....	13
4.2 Customer Service	13
5.0 DISPOSAL.....	13

SPECIFICATIONS

BMRX-300 GENERAL SPECIFICATIONS

Power Supply:	115/230 VAC, 50/60 Hz	
Supply Tolerance:	-15% to +10%	
Load:	7 VA	
Fuse:	2 AMP 250V TR5 Time Lag PCB mount	
Ambient Temperature: (Electronics)	-40°F to +131°F (-40°C to +55°C)	
Process Temperature:	400°F (204°C)	
Enclosure Type:	4X / IP66	
Enclosure Material:	Die cast aluminum, powder coat finish	
DPDT Relay Output:	10 Amps 250 VAC	
Fail Safe:	Switch selectable "High" or "Low" level modes	
Time Delay:	Selectable 5 seconds (default); programable to 30 seconds	
LED Status Indication: (optional)	Paddle rotating	Rotating GREEN
	Paddle covered	Solid RED
	Instrument Fault	Flashing YELLOW
Status Relay Output:	200V 1.5Amp AC or DC SPST-Normally Open	
Mounting:	1-1/4" NPT, 1-1/2" NPT, 1-1/2" Tri-clover	
Approvals:	Hazard Location Rating C/US Class II Div I Groups E, F & G	
Standards:	UL 1203:2013Ed.5+R:16Feb2018 CSA C 22.2#25:2017Ed.4 UL 61010-1:2012 CSA C22.2#61010-1-12:2012	
	Conforms to UL STD 1203 Certified to CSA STD C22.2 #25	
Conduit Entries:	3/4" NPT	
Shaft Seal:	1/2 micron, 30 PSI	



Intertek
5003113

SAFETY

SAFETY SUMMARY

Review the safety precautions to avoid injury and prevent damage to equipment.

The product should be installed, commissioned, and maintained by qualified, authorized personnel only.

Install according to instructions. Field wiring should conform to all national and local electrical codes and any other agency or authority having jurisdiction over the installation.

Use electrical wire that is sized and rated for the maximum voltage and current of the application. The internal grounding terminal shall be used as the equipment grounding means, and that the external terminal is only a supplemental bonding connection where local authorities permit or require such a connection.

Observe terminal and relay contact ratings on the nameplate and in the installation manual.

Ensure the enclosure cover is in place and secured tightly during normal operation. In potentially wet environments, thoroughly seal all conduit entries.

If this product is used in a manner not specified by the manufacturer safety protection could be compromised.

If dissimilar metals are used to mount the level control, the enclosure should be inspected for galvanic action every three years.

Safety Terms and Symbols



WARNING: Warning statements identify conditions or practices that could result in injury or loss of life. Risk of electrical shock.



CAUTION: Caution statements identify conditions or practices that could result in damage to this product or other property.

INTRODUCTION

1.0 INTRODUCTION

The BinMaster BMRX-300 is a rotary level sensor that provides reliable point level detection in bulk solids, including powder, pellet, and granular materials. The unit's status is continually monitored, and its fail-safe circuitry will fail to a "safe" condition on the event of a failure or power failure. A visual LED array continually indicated the sensors status, giving a quick visual of paddle rotation, covered condition or fault condition. A status relay output is also provided for external monitoring of the sensor status.

The BMRX-300 motor rotates the drive shaft and paddle at 1 RPM. When the material fills to the level of the indicator paddle, it causes the paddle to stop rotating indicating a covered condition. When the material falls away, the paddle resumes rotating to indicate an uncovered condition.

2.0 INSTALLATION

2.1 Mounting Summary

The BMRX-300 has three optional process fittings available to mount the indicator; 1.25" NPT, 1.5" NPT, or 1.5" tri-clover fitting. The BMRX-300 can be mounted using a mounting plate, welded in couplings, or mating the tri-clover fitting with a flanged end with an internal diameter big enough for the paddle to fit through.

Mounting Plates

Mounting plates allow installing a completely assembled rotary through the vessel side or top. The mounting plates have 6 bolt holes equally spaced on a 7-inch bolt circle. Mounting plates are available with 1.25" or 1.5" NPT half or full couplings dependent on the process fitting size of the rotary.

Half couplings are used for all side mount installations or if top mounting a rotary without using a guard pipe.

Full couplings are for top-of-vessel installations when using shaft extensions and shaft guard pipes. Do NOT use full couplings for side mounting. The void on the process side of a full coupling could allow material to pack in the void and interfere with rotation of the rotary shaft.

Cut a hole in the vessel wall large enough for the paddle to fit through. Place the gasket between the mounting plate and the vessel and install 6 mounting bolts through the mounting holes to secure the plate to the vessel.

Mounting without Mounting Plates

Select a coupling or tri-clover fitting that matches the size of the process fitting on the rotary. Cut a hole in the vessel big enough to fit the coupling through the vessel wall. Weld the coupling to the vessel wall to seal out moisture and dust.

Mounting Plates

Mounting plates are needed when a completely assembled rotary is mounted on the bin wall from the outside. Cut a 5-1/2" hole in the bin. Drill six bolt holes around the hole to match the mounting plate. Bolt the plate, with the unit attached, into place. Mounting plates are available in carbon or stainless steel

Full Coupling

For use with all rotary level controls. Full coupling is used for top-of-bin installations where shaft extensions and shaft guards are used.

Figure 4

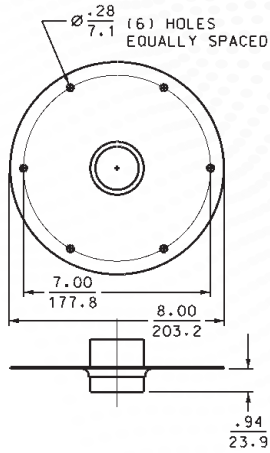

Half Coupling

For use with all rotary level controls. Half coupling is used primarily for side of bin installations.

Figure 5

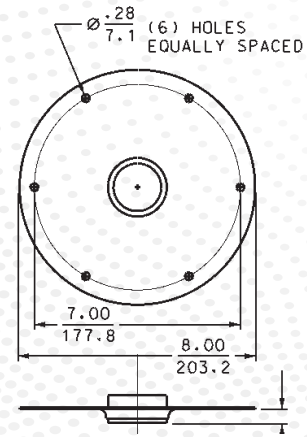

2.2 Locating and Mounting

SIDE MOUNT

1. Determine location and cut hole inside of bin to fit outside diameter of 1-1/4" pipe coupling (1.950").
2. Weld on half of standard 1-1/4" pipe coupling to bin wall flush with inside of bin.
3. Insert hub into coupling and turn rotary so conduit entries are pointed down toward the ground.
4. Screw paddle into place and replace lock pin.
5. Shaft and paddle should be shielded in low level mounting to protect from material flow.
6. For side mounting, a solid coupler is recommended.

Figure 1

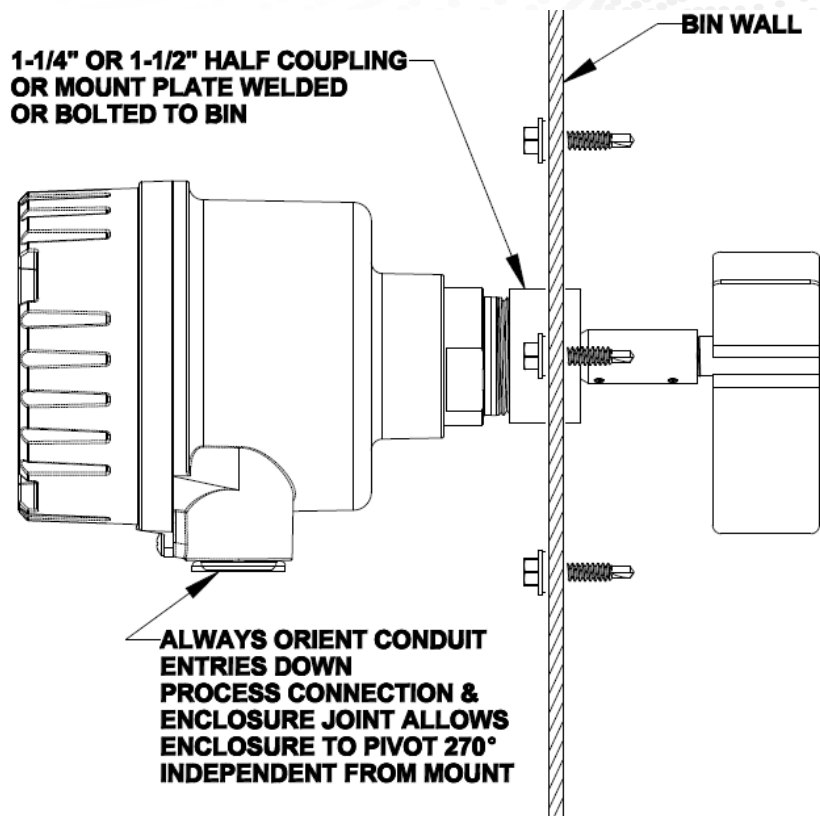

TOP MOUNT

1. Determine mounting location and cut a hole in top of bin to fit outside diameter of 1-1/4" pipe coupling (1.950").
2. Position coupling halfway into bin and weld to bin.
3. Turn rotary so conduit openings are in desired location.
4. Add 1/4" extension pipe of desired length with standard 1/4" coupling on bottom end.
5. Cut 1-1/4" support pipe approximately 4" shorter than overall length of 1/4" pipe shaft if used with flexible coupling.
6. Insert 1-1/4" pipe into coupling and tighten.
7. Insert paddle into 1/4" coupling and drill holes for lock pins.

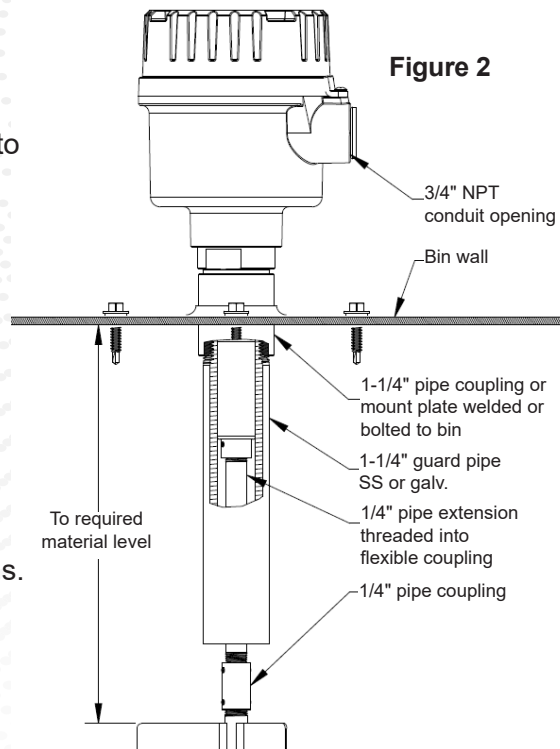
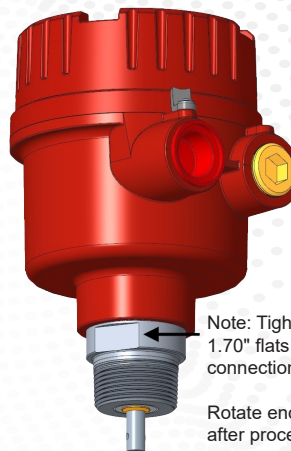

Figure 2

MOUNTING

Use the 1.70" flats provided on the process connection for tightening the instrument into the mounting coupler or mounting plate.

The enclosure can be rotated 360 degrees after the process connection is tight. NOTE: For side mount application, rotate enclosure conduit entries DOWN after the process connection is tight.



Note: Tighten/loosen only using the 1.70" flats provided on the process connection.

Rotate enclosure conduit entries down after process connection is tight.

Mounting Orientation

To prevent moisture or humidity from entering the unit when mounted on the side of the bin, the rotary MUST be mounted with the conduit entries facing down.

Conduit Seal

When installing the rotary in environments where moisture or moist air may enter the unit through the electrical conduit, the conduit openings should be sealed with an appropriate duct seal compound or putty.

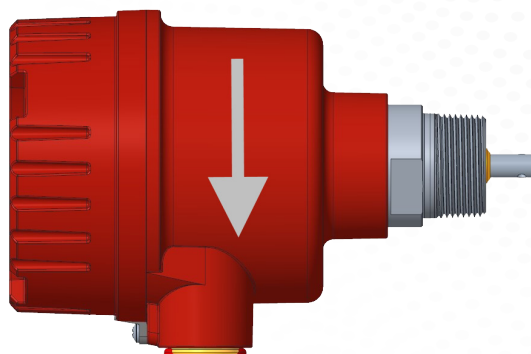

NOTE: Conduit entries must be fitted with a suitable sealing device for the Hazardous Location. All conduit entries must be sealed and if any conduit entry blanking plugs are removed or replaced, they must be fitted with a suitable certified sealing device.

2.3 Input Power and Field Wiring

The BMRX-300 operates at 115 VAC or 230 VAC supply voltages. Field wiring should conform to all national and local electrical codes and codes of any other agency or authority with jurisdiction over the installation. For power input, use wire sized and rated for the maximum voltage and current according to equipment ratings with a temperature rating of at least 70°C. For SPDT switch output, use wire sized and rated for the maximum voltage and current for the application, up to 250 VAC 10A, and has a temperature rating of at least 70°C. Installation must be done by qualified personnel.

NOTE: Open the screw terminals fully before inserting wiring.

BMRX-300 Wiring Input Power

Power input to BMRX-300 is connected to the POWER terminals labeled LINE L and N.

AC Models

On AC models, if one of the conductors is grounded, connect to the N terminal. Connect the ungrounded conductor to the L terminal. If neither conductor is grounded, connect one of the N terminal and the other to the L terminal.

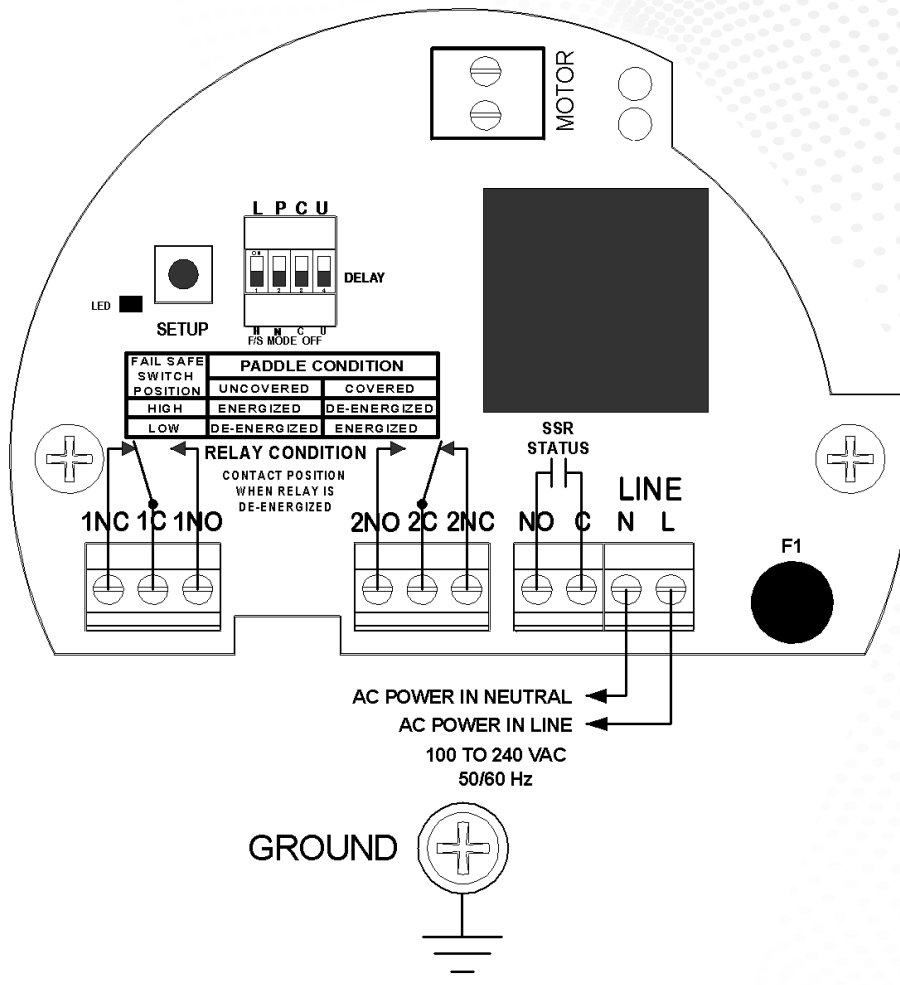

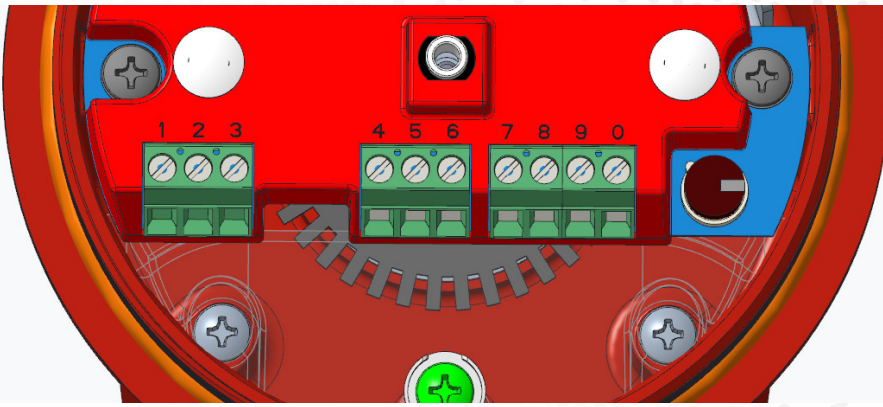

Relay Outputs	Status Relay	Power
1 1NC	7 NO	9 Neutral
2 1C	8 C	0 Line
3 1NO		
4 2NO		
5 2C		
6 2NC		

⚠ 2.4 Grounding

An equipment grounding connection (earth ground) to the rotary is required for safety. Connect the ground conductor to the green grounding screw inside the enclosure.

3.0 DPDT Relay

The DPDT relay utilizes a Fail Safe selector DIP switch. There are two positions for the switch, High (H) and Low (L). A Fail Safe condition means the DPDT relay contact positions are set so in the event of a power failure the relay will be de-energized and the contacts will indicate a condition that is deemed safe for the application.

3.1 Fail Safe High

Fail Safe High means that the relay will be energized when the paddle is rotating (uncovered) and will de-energize when the paddle is covered. In this mode, a power failure will cause the relay contacts to indicate that the paddle is covered, whether it is or not.

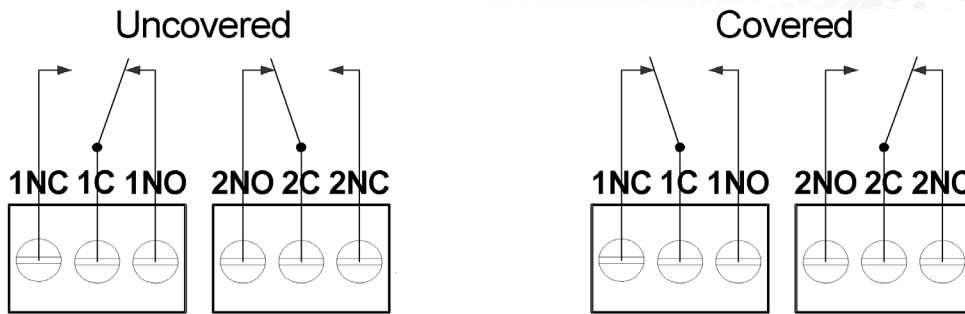

3.2 Fail Safe Low

Fail Safe Low means that the relay will be de-energized when the paddle is rotating (uncovered) and will energize when the probe is covered. In this mode, a power failure will cause the relay contacts to indicate that the paddle is uncovered, whether it is or not.

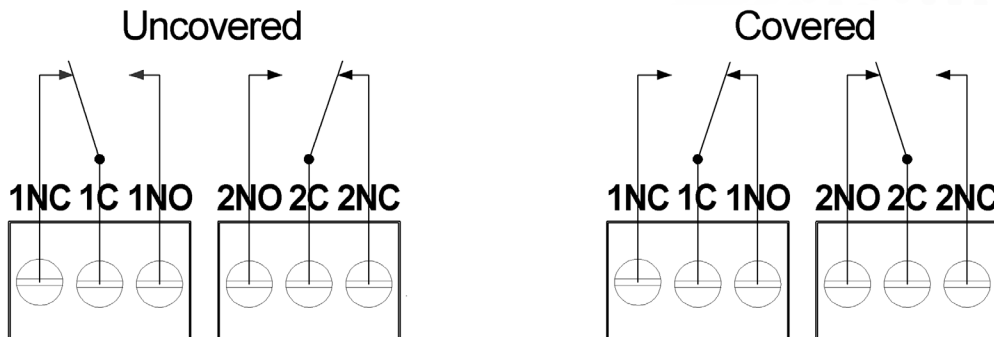

3.3 Status LED Indication

The visual LED array indicates the status of the sensor. The three statuses are:

- Paddle rotating Rotating GREEN LEDs
- Paddle covered Solid RED LEDs
- Instrument fault Flashing YELLOW LEDs
- Loss of input power LEDs OFF

3.4 Status Relay Output

The Status Relay indicates the status of the BMRX-300. There are two modes of operation for the Status Relay, Normal (N) and Pulse (P). The mode for the Status Relay is selected by the #2 position of the DIP switch.

In the Normal (N) position, the Status Relay is energized (C and NO closed) when the BMRX-300 is operating correctly. In this mode, shaft rotation is detected or there is a covered indication of paddle.

If the shaft is not rotating and the "covered switch" is not indicating covers, then the BMRX-300 will go into a Fault condition (C and NO open). A Fault condition is indicated by both the Status Relay and the DPDT output relay de-energizing, and the visual LED array pulsing YELLOW.

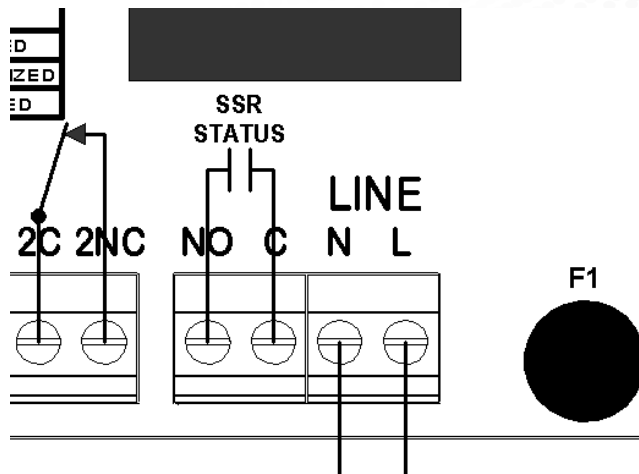

3.5 Time Delay

The BMRX-300 has selectable time delay for the DPDT relay contacts. This time delay can be selected for switching from an uncovered to a covered condition or for switching between a covered to an uncovered condition or both.

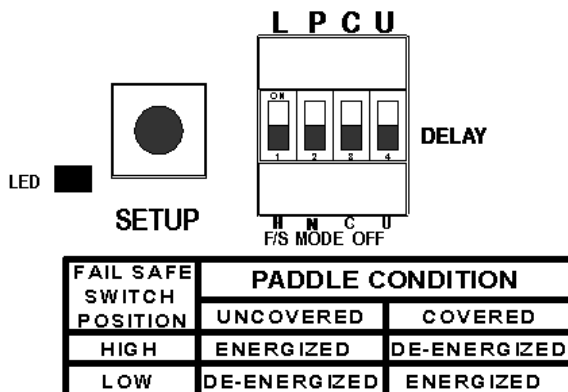

The time delay is selected by time delay DIP switches #3 and #4. Switch 3 is for selecting a time delay for going from an uncovered to a covered condition. Switch 4 is for selecting a time delay for going from a covered to an uncovered condition. When both switches are OFF, there is no time delay. When the switch is ON, there will be a time delay for that condition.

By default, the time delay is set to 5 seconds for both switches. This time delay can be changed by using the SETUP push button switch on the circuit board. The Delay Time can be set for each switch independently or for both together if the same delay time is desired for both "delay on covered" and "delay on uncovered". The maximum time delay that can be programmed is 28 seconds. Follow the procedure below to change the delay time.

3.6 Changing the Delay Time

Step 1. Select the switch for the delay time that you want to change by placing it in the ON position. Switch 3 is for "Delay on Covered". Switch 4 is for "Delay on Uncovered". The new delay time will be set for switch or switches in the ON position. At least one of the delay switches must be ON in order to enter the programming mode.

Step 2. Press and hold the SETUP switch for three seconds to initiate the programming mode. The LED will flash fast for these three seconds to indicate entry of the program mode. Releasing the SETUP switch during this initial three second period will abort the program mode and leave the delay times unchanged.

Step 3. After the three seconds has passed, continue holding the SETUP switch for the desired amount of delay time in seconds. The LED stops flashing fast and will blink every second for indication of the delay time so far. Each one second flash is one second of delay time.

Step 4. After the desired amount of delay has passed, one second for each blink, release the SETUP switch and the delay time will be set for the delay switches that are in the ON position. You may enter up to 28 seconds. Holding the SETUP switch longer than this will have no effect and limit the delay to 28 seconds.

4.0 WARRANTY AND CUSTOMER SERVICE

4.1 Limited Warranty

LIMITED PRODUCT WARRANTY. Products manufactured by Seller are warranted for a period of one (1) year from date of shipment against defective materials and workmanship (the “Warranty Period”). SELLER MAKES NO OTHER WARRANTY, EXPRESS OR IMPLIED, AND ANY WARRANTY OF MERCHANTABILITY OR FITNESS FOR A PARTICULAR PURPOSE IS HEREBY DISCLAIMED AND EXCLUDED.

This limited warranty does not extend to labor charges or other costs related to the removal and/or replacement of defective products or services. Any technical advice or services furnished by Seller with respect to the products is given without charge, and Seller assumes no obligation or liability for the advice given or results obtained, all such advice being given and accepted at Buyer's sole risk and expense. If the products are being acquired for resale, Buyer will make, in connection with any such resale, only those warranties contained herein and will indemnify Seller and its officers, directors, agents, employees, affiliates, successors, and assigns against any claims, causes of actions and judgments which arise from any representations, warranties, or agreements made by or entered into by Buyer, other than those contained herein.

WARRANTY EXCLUSIONS. Notwithstanding Seller's Limited Product Warranty, products that have been or are (1) damaged by accident, corrosion, the elements, abuse, misuse, misapplication, vandalism, negligence, improper transportation, handling, storage, use or lack of proper and reasonable maintenance, (2) repaired or altered by anyone other than Seller or its authorized service providers, (3) modified or altered without Seller's written authorization, or (4) specially manufactured by Seller as per specifications provided by Buyer, are expressly excluded from Seller's Limited Product Warranty.

4.2 Customer Service

BinMaster's toll-free Customer Service phone number is 1-800-278-4241. Call the Technical Service Department for support Monday through Friday from 8:00 AM to 5:00 PM Central Time. International customers call 1-402-434-9102 or techsupport@binmaster.com.

5.0 DISPOSAL

This product contains recyclable materials and electronics that can be easily separated and recycled by specialized recycling companies. Consult local authorities for proper disposal locations.



BinMaster: Division of Garner Industries LLC
Lincoln, NE
402-434-9102