

# **BINMASTER**

## QUICK SETUP GUIDE

# NCR-86 with Bindisc

### STEP 1

- > Place Bindisc on NCR-86, line up tabs. Attaches with a quarter-twist. Wait for Bindisc to power on displaying distance value.
- > Press OK button to enter the menu
- > If this is the first time Bindisc is attached, you will need to pick English as a language.
- > Use the arrow button to move down in the menu and press OK.

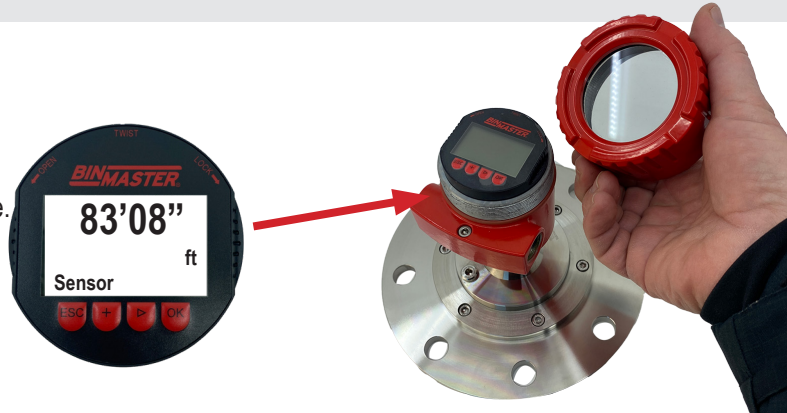

### STEP 2

- > This brings up the main menu press OK again to enter the Setup menu (a) Select measurement loop name (b). Select Type of medium (c). Select Liquids or Bulk Solids (d).

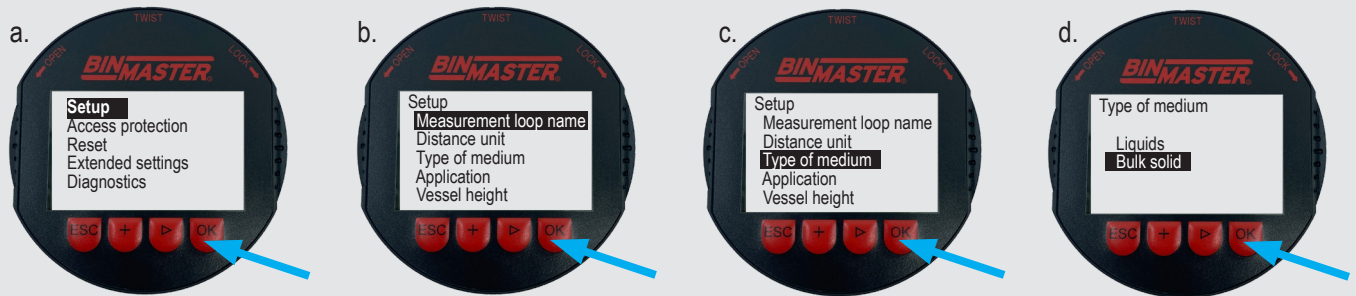

- STEP 3** - Press ESC (a) to go back to the Setup menu. Select vessel height (b) change to overall height of the vessel including the height of any cone or standoff pipe on the vessel, use the + button to increment the number under the cursor up one digit at a time and the > button to select the character that needs to be changed (c).

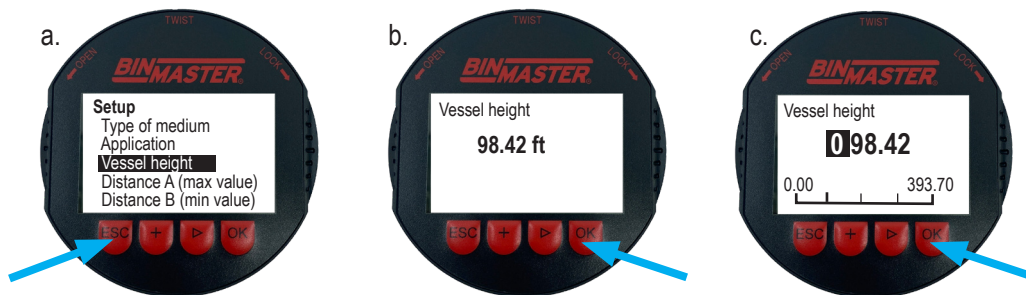

**STEP 4** - Press ESC to go back to the Setup menu and go to Distance A. Set this to the distance from the lens of the sensor down to the level of product that is considered full. In solids applications, this is usually at least 2 ft. At this distance the sensor will output 20mA.

**STEP 5** - Press ESC and go to Distance B. Set this to the distance from the sensor lens to where the silo is considered empty, this is commonly the same value as the Vessel height setting. When the distance measured equals this distance the sensor will output 4mA.

**STEP 6** - Press ESC until the distance measurement appear on the screen

**Basic Setup Complete!**

## LINEARIZATION

Linearization is used to calculate the volume of a cone bottom, and is calculated differently than the straight wall portion of the silo. It's likely that your radar will not read all the way to the bottom of the cone. If the sensor is properly located and aimed, the radar beam will most likely target the cone wall before reaching the bottom of the cone. Consult the factory if you have questions about sensor placement or aiming.

From the Main menu, press the arrow key and select Extended Settings (a). Then press ok. Arrow Down to Linearization (b), then press ok. Select the appropriate tank bottom shape (c) and click OK. Using arrow and + keys, enter the height of the cone (d).

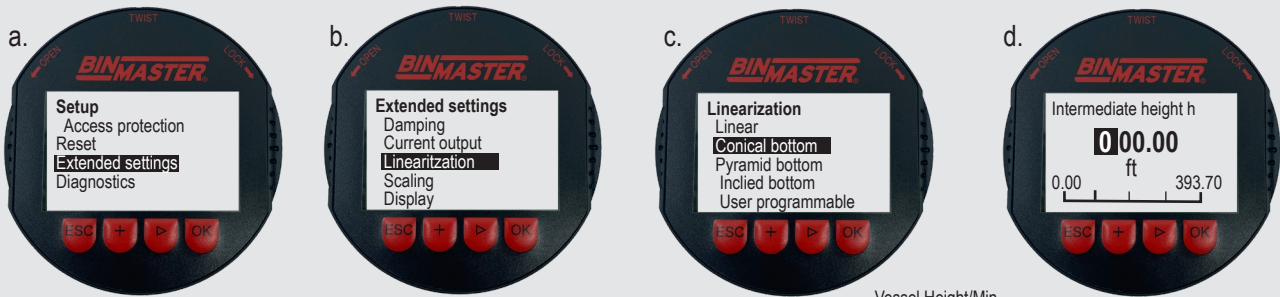

For example, if your silo has a straight wall of 25 ft. and a 5 ft. tall cone, then:

- > Tank height = 30 ft.
- > Distance B = 30 ft.
- > Linearization intermediate ht. = 5 ft.

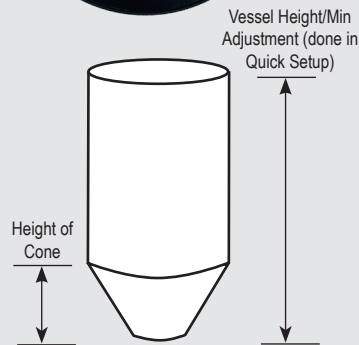

## FALSE SIGNAL SUPPRESSION

False signal suppression allows the sensor to blank out any echoes it may receive from structures inside the vessel other than the material. The following circumstances cause interfering reflections and can influence measurement:

- > Tall standpipes
- > Vessel installations such as structures, cages, or ladders
- > Agitators
- > Buildup or welded joints on vessel wall

**Note:** A false signal suppression detects, marks, and saves false signals so they are no longer considered in level measurement. In Extended Settings, arrow down to False signal suppression (a), then press OK. The Screen will read Change Now? – press OK (b). Then press OK on Create new (c). You are about to erase any signal that the unit currently sees – **so it's very important to only false signal suppress the portion of the silo that is empty.** It's best to get the silo as empty as possible during setup. **Enter a distance equal to or less than the distance to the material level (d).** If the tank is empty, you can enter the full vessel height.

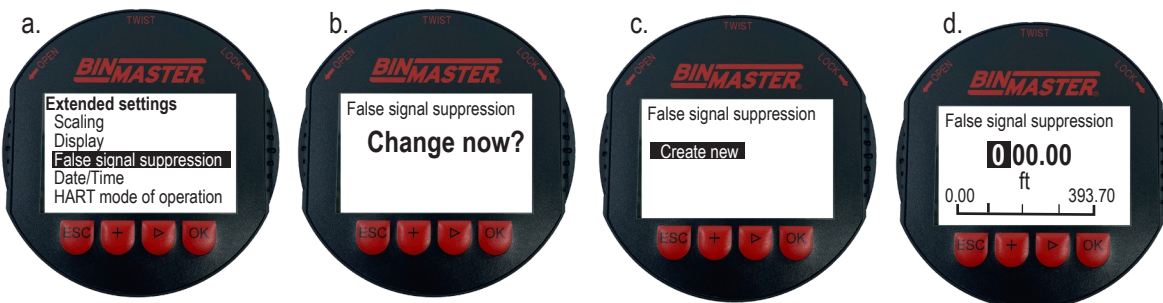

## SETUP COMPLETE

Screen should now show "Executing" with a processing bar underneath. When finished, "Change now" will show on the screen. Press [ESC] key to return to the menu.

