



# SmartBob A0



**OPERATING INSTRUCTIONS  
PLEASE READ CAREFULLY**

# TABLE OF CONTENTS

Safety Summary .....	3
Introduction .....	4
Specifications.....	5
Location and Mounting .....	6
Connections and Wiring .....	6
Power.....	6
Start Input .....	7
Override Input.....	7
4-20 mA Output .....	8
Relay 1 and 2 Outputs.....	9
Wiring Diagram.....	10
Air Purge System.....	11
User Interface .....	11
Run/Display Mode .....	12
Setup Menu .....	12
Calibrating the 4-20 mA Output.....	14
Motor Driven Operations .....	14
Cable Replacement Instructions .....	15
Probe Options.....	17
Limiting Stainless Steel Cable.....	19
Mounting Options .....	20
5-1/8" Floor Flange Template .....	21
7" Floor Flange Template .....	22
SureDrop Cable Release .....	23

# Safety Summary

Review the following safety precautions to avoid injury and prevent damage to the equipment.

The product should be installed, commissioned, and maintained by qualified and authorized personnel only.

Install according to installation instructions and comply with all National and Local codes.

Use electrical wire that is sized and rated for the maximum voltage and current of the application.

Properly ground the enclosure to an adequate earth ground.

Observe all terminal and relay contact ratings as called out on the nameplate and in the installation manual.

Ensure that the enclosure cover is in place and secured tightly during normal operation.

If this product is used in a manner not specified by the manufacturer the safety protection could be compromised.

## Safety Terms and Symbols



**WARNING:** Warning statements identify conditions or practices that could result in injury or loss of life. Risk of electrical shock.



**CAUTION:** Caution statements identify conditions or practices that could result in damage to this product or other property.

## Safety Precaution



Whenever personnel are going to enter a vessel that has a SmartBob mounted on it, the power to the SmartBob should be turned off. The SmartBob lowers a 2 pound weight (probe) of either metal or plastic material at a rate of up to 2 feet per second when it is taking a measurement. The weighted probe impacting personnel while it is descending could result in injury. Turning off the power to the SmartBob will disable the probe from dropping.

# INTRODUCTION

The SmartBob AO is a remote sensor for on-demand level measurements. It measures the vertical distance between the sensor and the surface of product in a tank or silo. During a measurement, the SmartBob AO lowers a weighted probe and measures the distance by counting pulses from an internal encoder. When the SmartBob AO detects a lack of encoder pulses (detection of product), it reverses direction and retracts the probe. The drop and retract encoder counts are compared to determine the distance to product. The distance to product measurement is then used to update a display and a 4-20 mA current transmitter. The display simply shows the measured drop distance while the 4-20 mA output provides a scale of the measurement based upon user-entered calibration points. There are also two user-configurable relays for level alarms, error and/or measurement indication. Measurements can be initiated by either the on-board interval timer or a dry contact closure on the Start terminals. Another dry contact input (Override terminals) can be used for inhibiting a measurement during the tank's fill cycle.

# SPECIFICATIONS

## Power Requirements

115 VAC Model 110 to 120 VAC at 60 Hz

230 VAC Model 225 to 235 VAC at 50/60 Hz

Power Consumption 12 VA continuous, 140 VA intermittent

Operating Temperature -4 to 158°F (-20 to 70°C)

Displayed Accuracy 0.25% plus +/-0.01 ft/m

Displayed Resolution 0.01 ft/m

## 4-20 mA Current Output

Mode 1 (recommended) Isolated (3,750 Vrms surge), external power required

Mode 2 Non-isolated, SmartBob AO powers the loop

Max Loop Resistance (Mode 1) Depends on external power

Max Loop Resistance (Mode 2) 500 ohms

Accuracy 0.35%

Resolution 16 bits maximum

Relay Outputs 220 VDC/0.24A, 250 VAC/0.25A, 30 VDC/2A

Start Input Dry contact only, 50 ms minimum closure time to trigger

Override Input Dry contact only, normally closed

Enclosure Type 4X

Mounting 3" NPT floor flange

Conduit Entry 3/4" NPT

Weight 25 lb.

Height 14-3/4"

Width 15-3/4"

Depth 7-1/2"

Air Purge Entry 1/4" NPT

Cable 316 stainless steel, 0.063" diameter, nylon coated

## Location and Mounting

The SmartBob AO should be mounted on the top of the storage vessel using a 3-inch NPT coupling and always in a vertical position. If a 3-inch NPT floor flange is used, it must be on a flat level surface to provide a vertical mount for the unit. For measuring dry solids which involve an angle of repose, it is recommended that the unit be mounted  $1/6$ th of the vessel diameter in from the side, see figure below. Two mounting flange templates, for a standard 3-inch NPT floor flange, are provided towards the end of the manual.

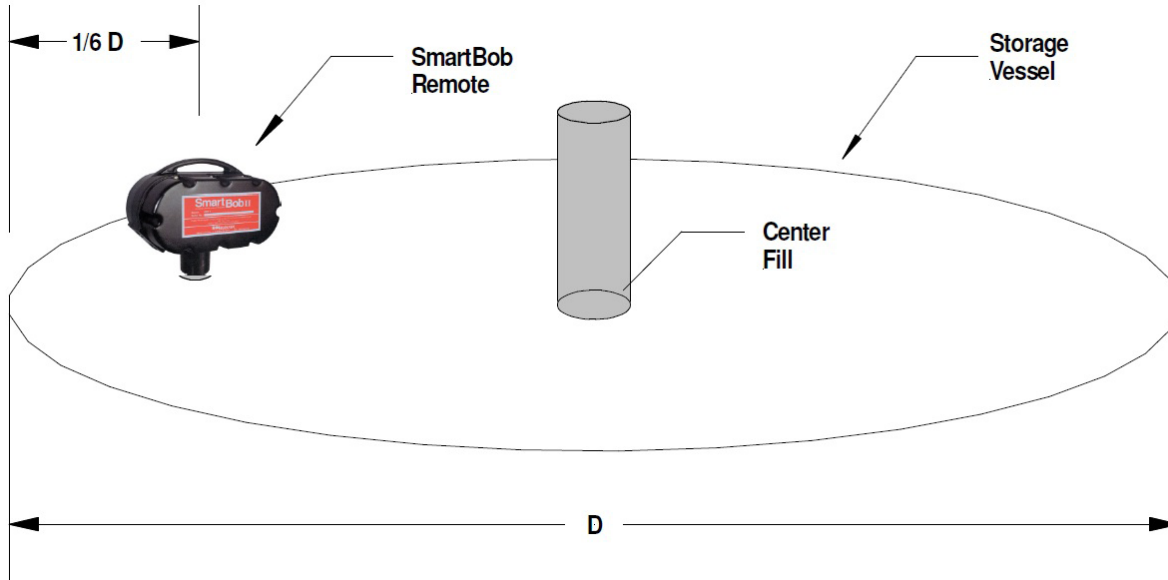

## Connections and Wiring

All field wiring should be installed according to local and/or national codes and have a temperature rating of at least  $85^{\circ}\text{C}$ . All wiring and jumper configuration should be made with AC power removed.

### Power

A disconnecting means should be provided to safely remove AC power from the SmartBob AO. Refer to the figure on the following page for connection of the power wiring. The AC power connects to the 2-pole terminal block located on the motor mount bracket. The left terminal should receive the line conductor and the right terminal should receive the neutral conductor.

A good electrical ground must be connected to the ground screw just to the left of the AC terminal block. This is required for safety, to bleed off any static buildup and to provide surge protection on the Override and Start inputs. It is recommended that the power cable be run in metal conduit.

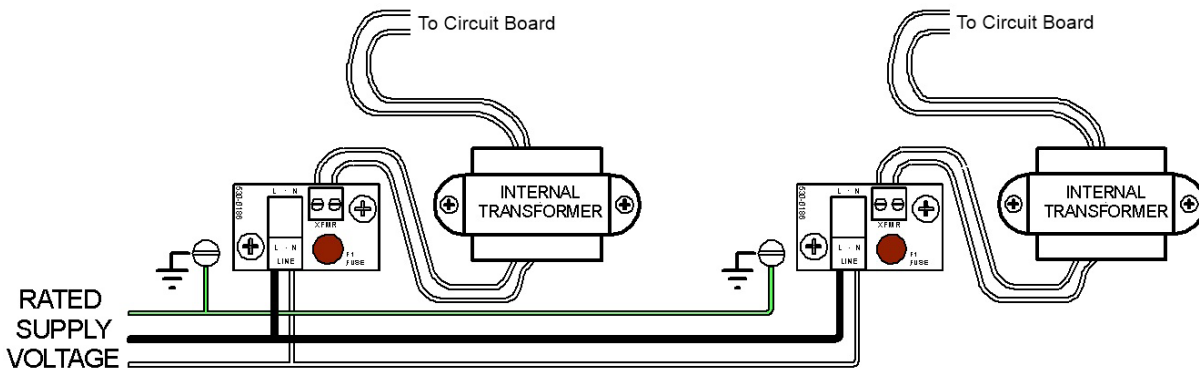

### Start Input

This input is used to initiate a measurement and should only be connected to a normally open set of dry contacts, such as a relay or a push button switch. Momentarily closing the contacts connected to these terminals will be detected as a start signal and initiate a measurement. An unshielded two-conductor cable between 14 and 20 AWG will work for a connection to this input.

### Override Input

This input is used to prohibit measurements from occurring and should only be connected to a normally closed set of dry contacts. Whenever the contacts connected to this input are open, all measurement requests will be ignored, whether it's the by the start input or the on-board interval timer. If this feature is not needed, then the two terminals labeled OVER-RIDE should be shorted together. These two terminals are shorted together at the factory. An unshielded two-conductor cable between 14 and 20 AWG will work for a connection to this input.

## 4-20 mA Output

This output will provide a 4-20 mA output scale based on the user-set calibration points and the last measurement. It will also provide a 22 mA signal following an error condition or when no measurement has been taken. There are two modes available, which require the user to properly set jumpers on the printed circuit board and to properly wire to the correct terminals. A 3-pole terminal block is provided for this output; however, only two of the terminals are used at any one time depending on the mode of use. An unshielded two-conductor cable between 14 and 20 AWG will work for a connection to this input.

Mode 1 provides for electrical isolation up to 3,750 Vrms. In this mode, the SmartBob electronics are isolated from the on-board 4-20 mA transmitter, the field wiring and the receiver (PLC). This mode does require that the DC loop power be provided externally or by the receiver (PLC).

To use Mode 1, first power down the SmartBob and locate the 4-20 OUT terminal. Next, connect the positive wire of the 4-20 loop wiring to the top terminal and the negative wire to the middle terminal. Do NOT connect anything to the bottom terminal. If the cable being used has a shield, do NOT connect it to anything at the SmartBob. Finally, locate jumpers J10 and J11 and move the shunts on both to pins 2 and 3 (upper position). See diagram below.

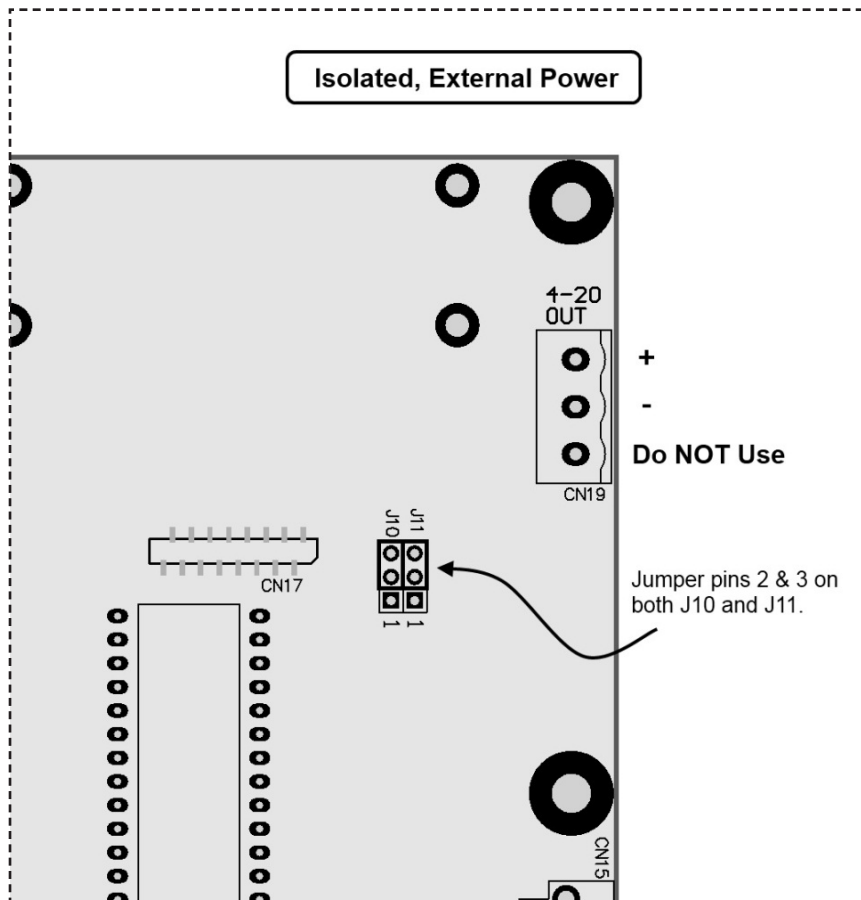

Mode 2 does not provide electrical isolation, but does provide the DC power for the loop. Be sure not to provide external power when using this mode.

To use Mode 2, first power down the SmartBob and locate the 4-20 OUT terminal block. Next, connect the positive wire of the 4-20 loop wiring to the middle terminal and the negative wire to the bottom terminal. Do NOT connect anything to the top terminal. If the cable being used has a shield, do NOT connect it to anything at the SmartBob. Finally, locate jumpers J10 and J11 and move the shunts on both to pins 1 and 2 (lower position). See diagram below.

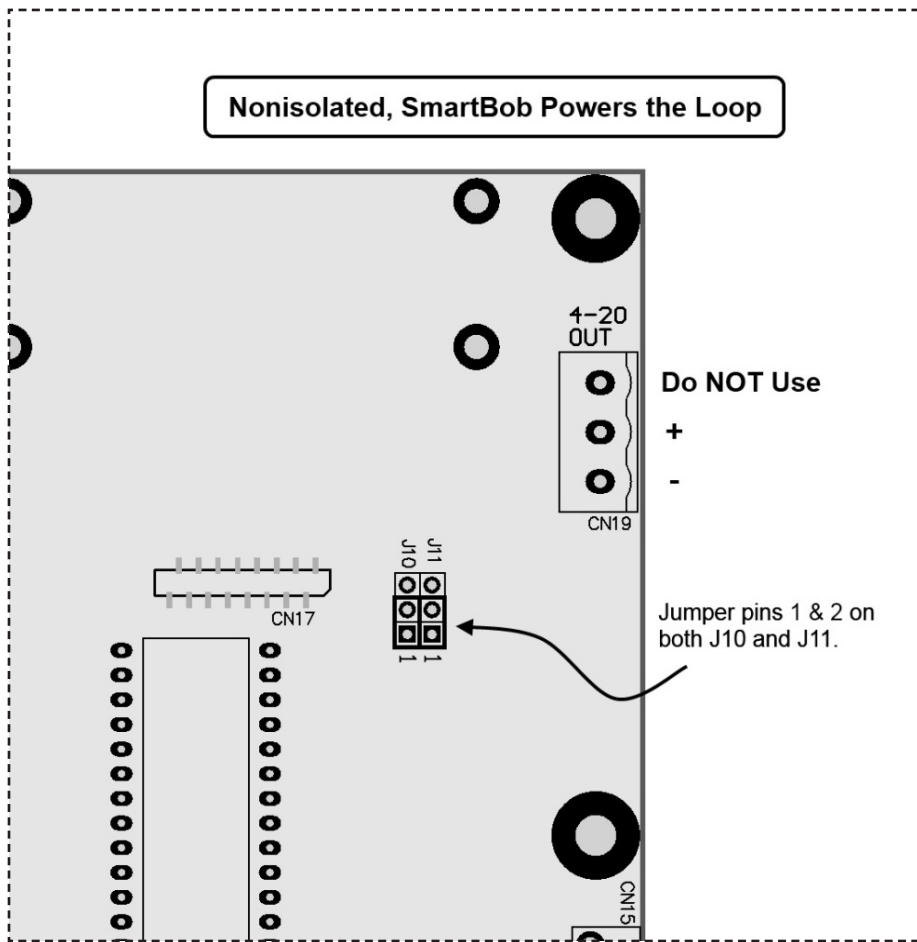

### Relay 1 and 2

There are two user-configurable, normally-open, relay outputs available for signaling a high-level alarm, a low-level alarm, an error alarm or a measurement indication. When set for a level alarm, the relay contacts will be closed when a measurement has exceeded a user-specified level. Once a measurement is taken with results that no longer exceed the user-specified level, the relay contacts will open. When set for an error alarm, the relay contacts will be closed when a measurement has resulted in an error. When a measurement successfully occurs without error, the relay contacts will open. When set for a measurement indication, the relay contacts will be closed during the measurement and then open when completed. With each relay output there is an LED on the circuit board that will turn on when the associated relay's contacts are closed.

There is a 2-pin terminal block available for connection to each relay output. These relays can switch low current signals and are not meant to power motors or high-wattage light bulbs. Be sure to read the voltage and current limitations in the Specification sections. An unshielded two-conductor cable between 14 and 20 AWG will work for a connection to this input.

**Wiring Diagram**

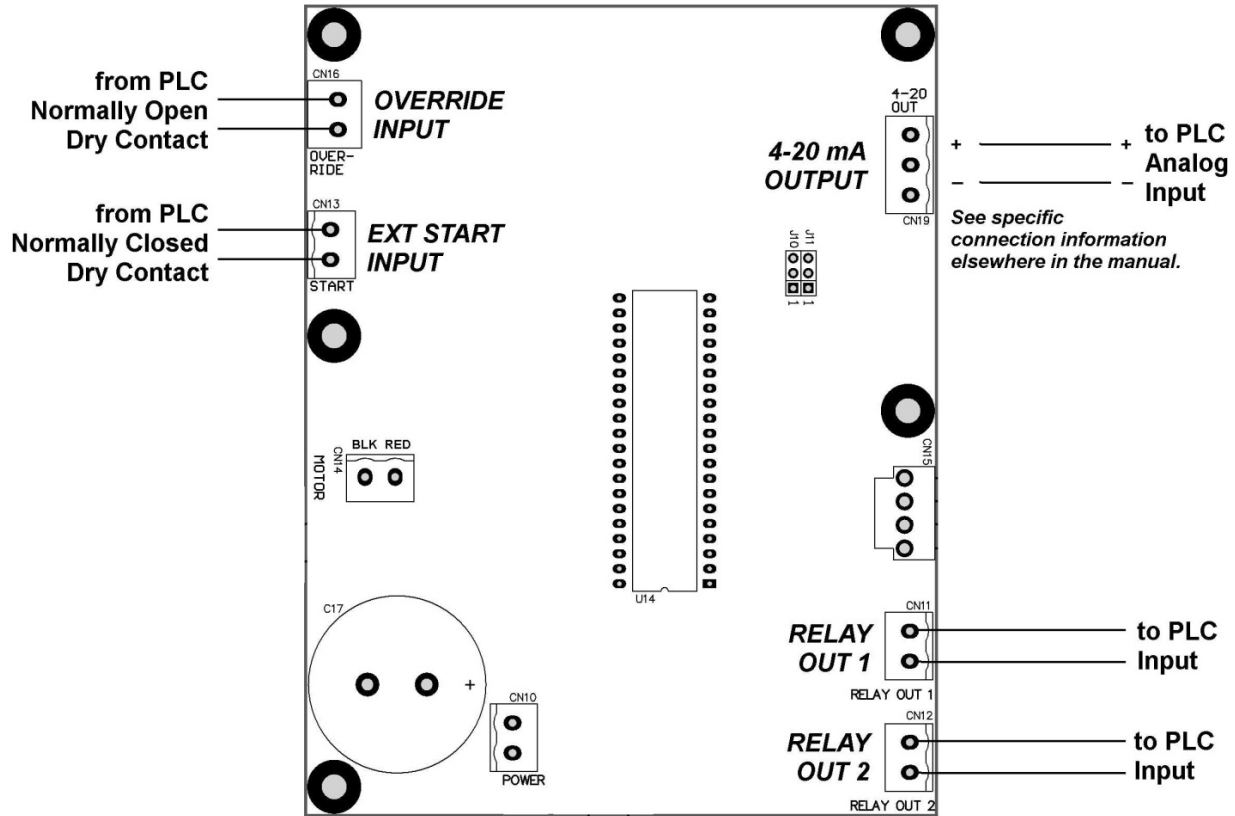

## Air Purge System

Located on the lower right side of each SmartBob AO is a 1/4" NPT air fitting. This fitting can be used to connect an external source of dry, clean air or noncombustible gas to the remote housing. By adding pressure to the remote housing that is slightly greater than that in the vessel, material and dust from the vessel is prevented from entering into the unit. The external pressure should be one (1) psi greater than the ambient pressure in the storage vessel and should be free from moisture and other contaminants.

## User Interface

The user interface consists of a small 2-line LCD display and four keys labeled UP, DOWN, MENU and CYCLE. All are located on the top portion of the circuit board inside the electrical side of the SmartBob AO. Refer to the diagram below and familiarize yourself with the user interface before continuing to the following sections, which explain how to use it.

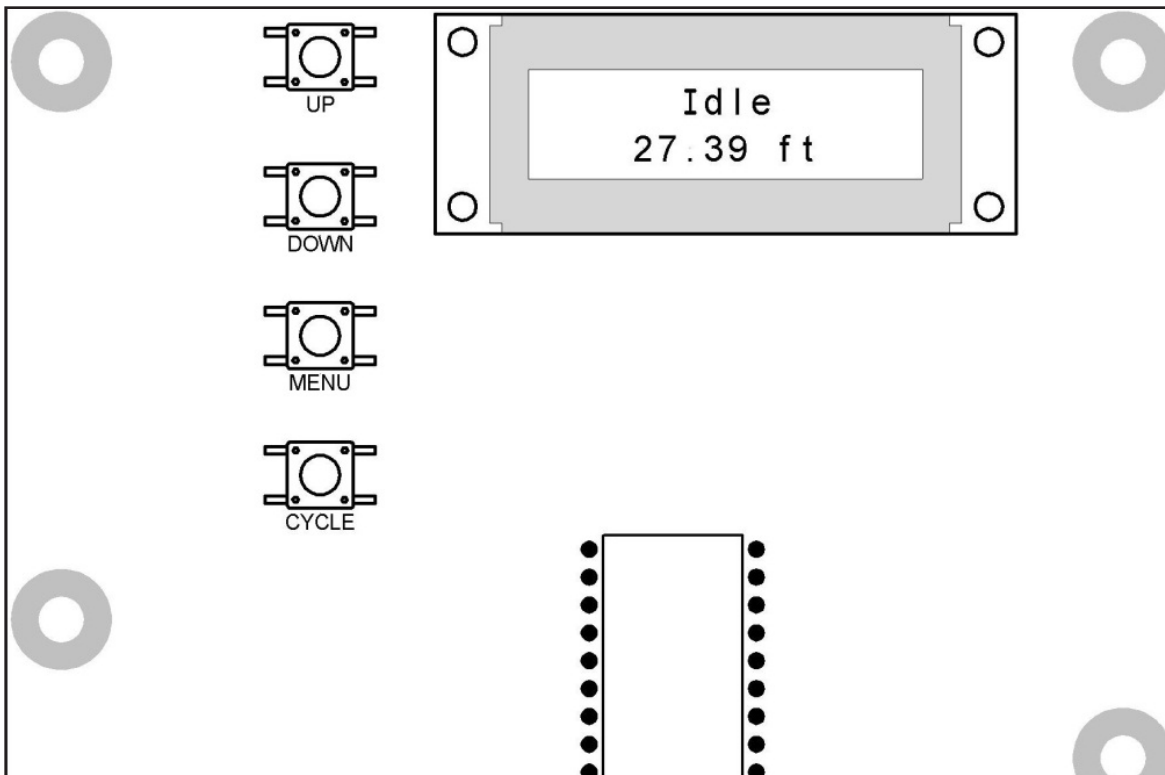

## Run/Display Mode

When not in the setup menu, the display will provide measurement progress and last measurement results.

The top line of the display will show status:

- Idle
- Dropping
- Retracting
- In Override
- Error

The bottom line of the display will show results of last measurement:

- Measurement distance in feet or meters
- No Results
- Stuck Top
- Stuck Bottom

## Setup Menu

In order to operate the setup menu, the electrical side of the SmartBob AO must be opened. After operating the setup menu, be sure to properly close and seal the SmartBob AO.

Press MENU to enter the setup menu. This is only accessible when not performing a measurement or other motor driven operation. Once in the setup menu, measurements and other motor operations will not occur.

Use UP/DN keys to change the displayed setting. Hold the key for repeated adjustments with automatic rate change.

Press MENU to accept the current setting and advance to the next setting. If at the last setting, pressing MENU will return to display/run mode.

If left in setup mode for 8 seconds without a key press, it will automatically return to run/display mode.

The settings available in the Setup Menu are as follows:

**Measurement Interval** – This is used to setup automatic re-occurring measurements. The interval can range from 2 min to 99 hours 59 minutes. It can also be disabled and is by default.

**Measurement Units** – This is for setting the units of measure that get displayed. It can be feet or meters. The default is feet.

**4mA Drop Distance** – This is for setting the drop distance associated with a 4 mA output. It can range from 0.00 to 409.59 feet or 0.00 to 124.84 meters. The default is 60.00 feet.

**20mA Drop Distance** – This is for setting the drop distance associated with a 20 mA output. It can range from 0.00 to 409.59 feet or 0.00 to 124.84 meters. The default is 0.00 feet.

**Maximum Drop Distance** – This is the maximum distance the SmartBob AO will allow the bob to drop, which can range from 0.34 to 409.59 feet or 0.11 to 124.84 meters. The default is 60.00 feet.

**Output Relay 1** – Normally open relay output that can be set to any of the following:

- Disabled (default)
- High-Level Alarm Drop Distance – Can range from 0.00 to 409.59 feet or 0.00 to 124.84 meters.
- Low-Level Alarm Drop Distance – Can range from 0.00 to 409.59 feet or 0.00 to 124.84 meters.
- Error Alarm
- Measurement Indication

**Output Relay 2** – Same as Output Relay 1.

## Calibrating the 4-20 mA Output

Considering the tank shown at right, if you wanted 20 mA to indicate full and 4 mA to indicate empty, then set the 4 mA drop distance to 6.00 feet and the 20 mA drop distance to 0.50 feet. Any measurement of 6.0 feet or more (empty) will drive the output to 4 mA, any measurement of 0.5 feet or less (full) will drive the output to 20 mA and any measurement in between 0.5 and 6.0 feet will be scaled. For example, a drop distance of 3.25 feet would produce 12 mA output (50% full).

It is also possible to reverse the polarity, so that the full point would provide 4 mA output and the empty point would provide 20 mA output. In this case, simply set the 4 mA drop distance to 0.50 feet and the 20 mA drop distance to 6.00 feet. Any measurement of 6.0 feet or more (empty) will drive the output to 20 mA, any measurement of 0.5 or less (full) will drive the output to 4 mA and any measurement in between 0.5 and 6.0 feet will be scaled.

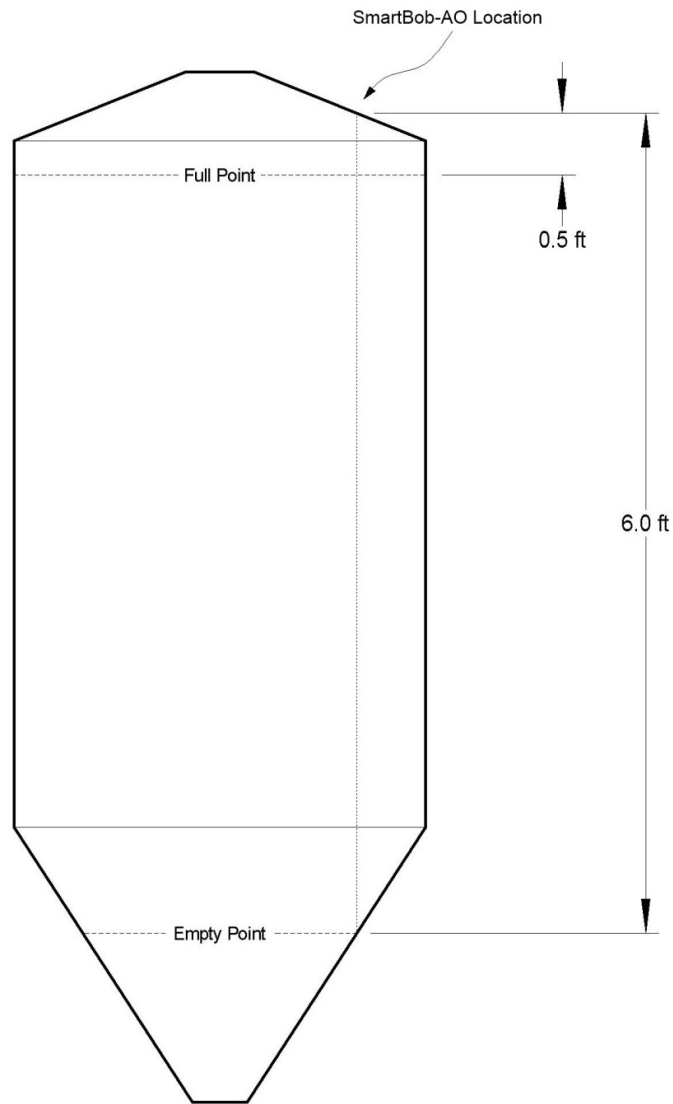

## Motor Driven Operations

Press the CYCLE button to perform a test measurement cycle. The display, the 4-20 mA output and the relays will not be updated based on the results of a test cycle.

Press and hold the DOWN button to lower the probe. It will stop when the key is released, when it hits product or when the max drop limit is reached.

Press and hold the UP button to retract the probe. It will stop when the key is released or when it is fully retracted.

Momentarily short the START terminals to initiate a measurement.

# Cable Replacement Instructions

## Before Starting

Disconnect the power source. Remove the flat cover on the back of the remote housing.

## Cable Replacement

1. Remove the cable from the supply pulley by pressing the "CYCLE" button on the top of the PC board. While keeping the cable taut, pull on the cable as the cable spools off the pulley. When the line is all paid out, the motor will reverse and try to rewind the cable. Hold the cable tight so it cannot rewind. The motor should now be shut off. Discard old cable.
2. Attached to the end of the new cable is a terminal crimp ring. Attach this crimp ring to the supply pulley flange as shown in the illustration.
3. To rewind onto the supply pulley refer to the "Loading the Supply Pulley".
4. After loading the supply pulley skip to "Threading the Cable".

## Kit Replacement

1. Loosen the 1/4" set screw located on the hub of the supply pulley then remove the supply pulley assembly.
2. Remove and discard the old supply pulley and cable.
3. Assemble the new supply pulley replacement kit.
4. Skip to "Threading the Cable".

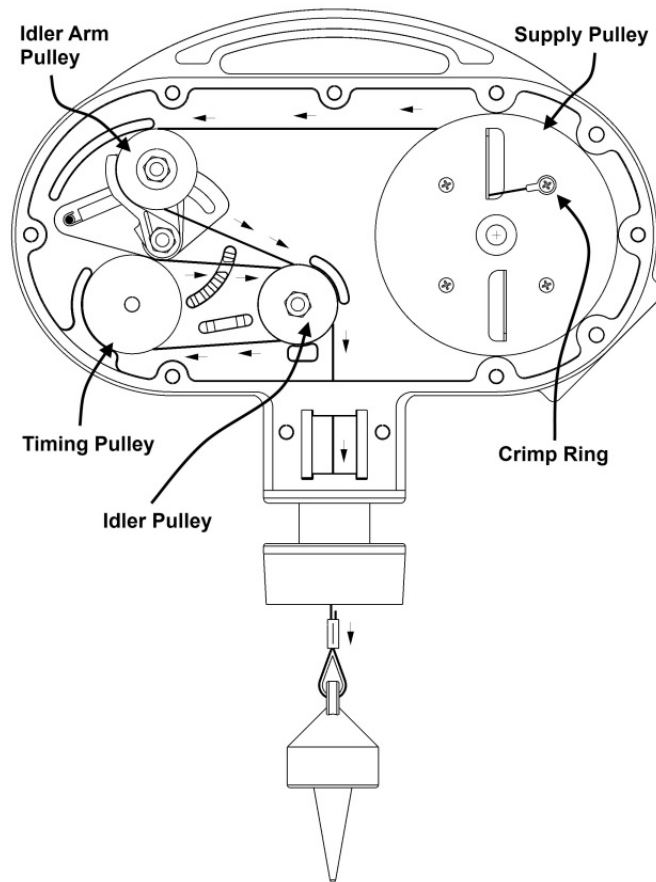

## Threading the Cable

Thread the cable over the top of the idler arm pulley, over the top of the front groove of the idler pulley, under the timing pulley, then over the top of the back groove of the idler pulley as shown in the illustration. Then thread the cable down through the brushes and threaded mount assembly. Refer to the "SureDrop Cable Release System" for attaching the SureDrop assembly and weighted probe.

**NOTE:** At this point you should refer to the attached manual instruction sheet "Limiting Stainless Steel Cable". Follow steps 2 through 6.

## Loading the Supply Pulley

1. Reconnect the power source.
2. If loading the supply pulley is necessary, pull the cable taut. Load supply pulley by pressing the UP button located on the circuit board. Pressing this button will start the supply pulley turning in a clockwise direction, with the cable winding over the top. Keep the cable taut until the pulley is full. When the supply pulley is full, release the button.
3. Replace the cable wiper brushes and reattach the cover.

## Probe Options

### B1 and B2



This stainless steel probe is designed for granular materials from 20 lb. per cubic foot and greater. This probe is shipped standard with every SmartBob AO. A 416 SS magnetic version is order code B2.

### B3



This probe is a hollow inverted 4-inch cone made of stainless steel and is designed for bulk products with a density from 5 lb. to 20 lb. per cubic foot. This probe should not be used in liquids.

### B4

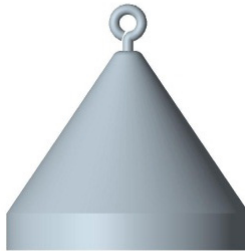

This probe is a hollow inverted 6-inch cone made of stainless steel and is designed for bulk products with a density from 1.5 lb. to 20 lb. per cubic foot. This probe may also be used in liquid applications.

**B5 and B6**

This probe is designed for granular material with a density from 20 lbs. per cubic foot and greater. This probe is a digestible bottle that is filled with 32 oz. of paraffin wax. The digestible bottle is made from an engineering plastic which will not damage the material handling auger in the unlikely event that the probe should become separated from the unit. Order code B6 is an empty bottle option of this probe which is to be filled in the field to a weight of about 32 ounces.

**B9**

This probe is a 6-inch stainless steel hollow sphere and is designed for use in liquids, slurries, and for light powder applications.

## Limiting Stainless Steel Cable

It is important to limit the length of cable on the SmartBob AO, so that the probe is not lowered into an airlock, screw conveyor, or any other area that the probe might become trapped in. The SmartBob AO is shipped with 90 feet of cable unless otherwise specified. Disregard these instructions if the unit was ordered with the exact amount of cable necessary for your vessel. This procedure for limiting the cable should be done before the unit is installed.

1. Remove the cable from the supply pulley by pressing the CYCLE button on the printed circuit board. Keeping the cable taut, pull on the cable as the cable spools off the pulley. When the line is all paid out, the motor will reverse and try to rewind the cable. Hold the cable tight so it cannot rewind. The motor should now be shut off.
2. From the throat or pipe extension of the SmartBob AO, measure the height of your vessel or the maximum distance you want the probe to travel into your vessel then add 48" to that length.
3. Cut the stainless steel cable at this distance (vessel height + 48").
4. Refer to "SureDrop Cable Release System" assembly instructions in this manual.
5. Thread the stainless steel cable through the SureDrop, thimble and probe as shown.
6. Tighten and crimp the noose around the thimble. Locate and crimp the round crimp as shown.
7. Test crimp by pulling on the cable and probe.
8. Rewind the cable onto the supply pulley or lower the cable and probe into the vessel. To rewind onto the supply pulley: Pull the cable taut. Load the supply by pressing and holding the UP button located on the circuit board. Pressing this button will start the supply pulley turning in a clockwise direction, with the cable winding over the top.

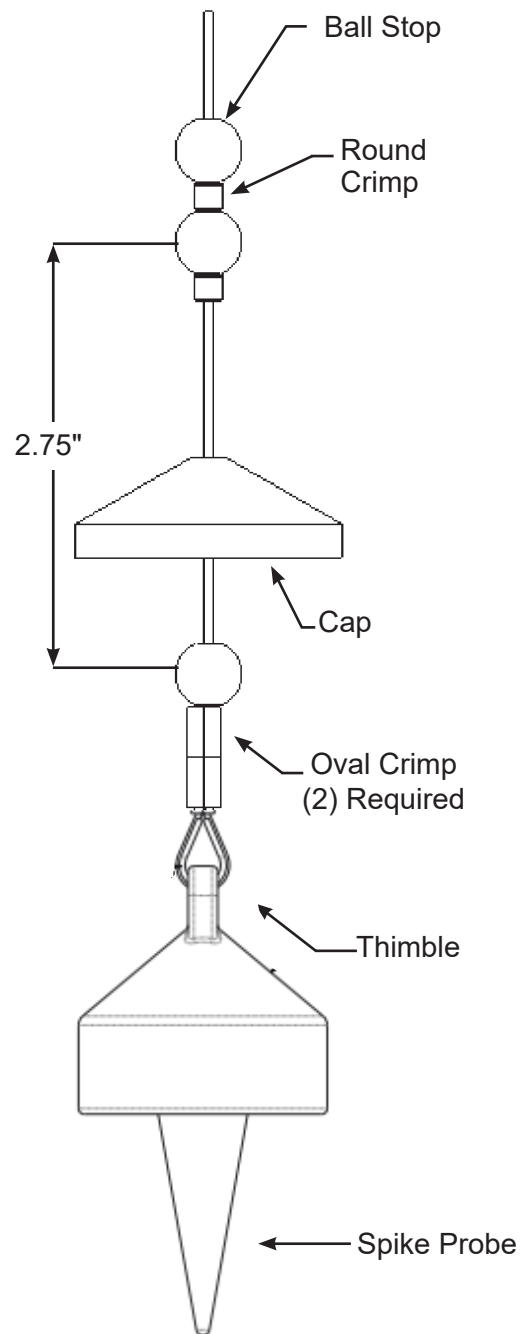

# Mounting Options

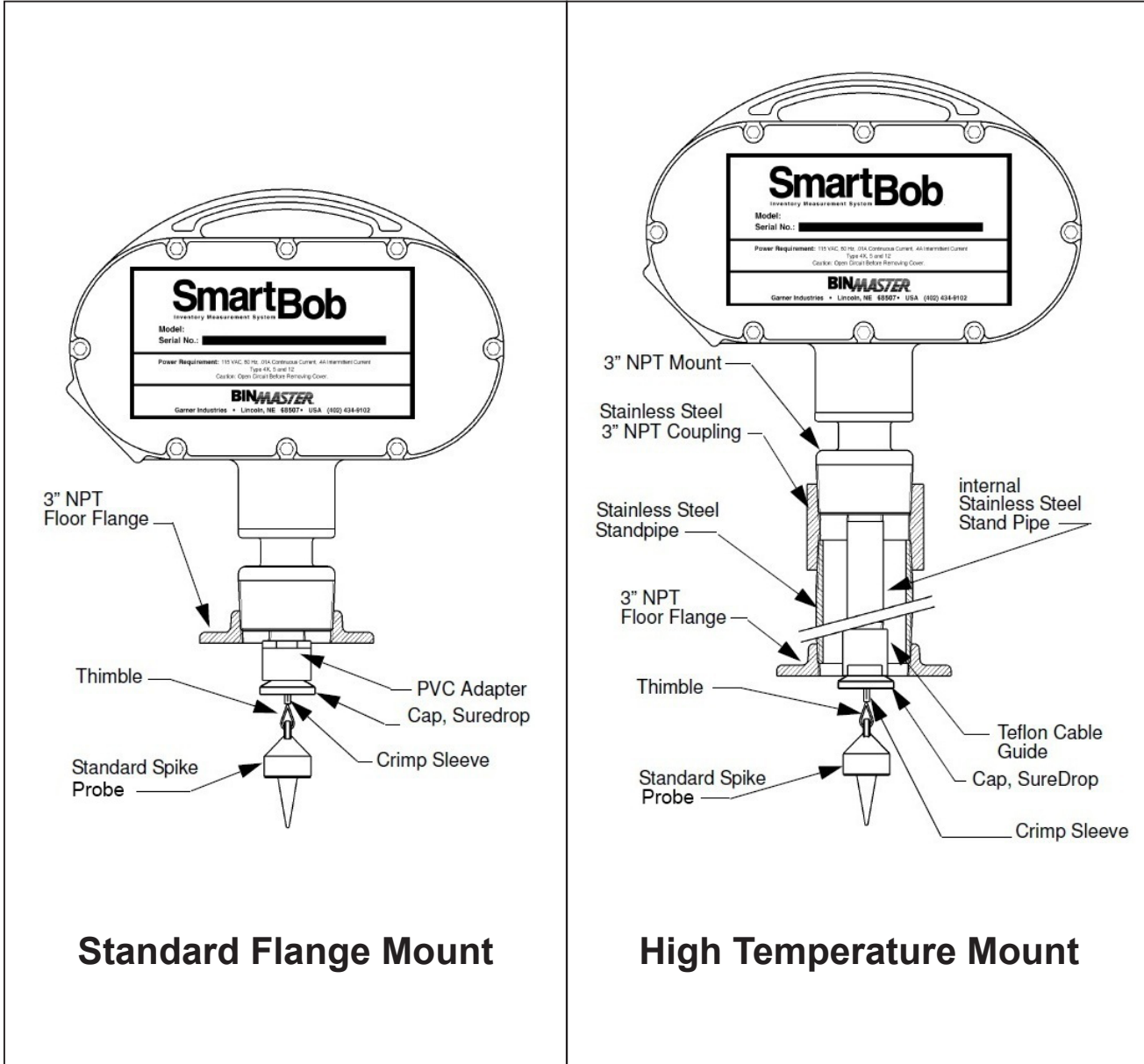

**SMARTBOB REMOTE MOUNTING TEMPLATE**  
**5 inch floor flange**

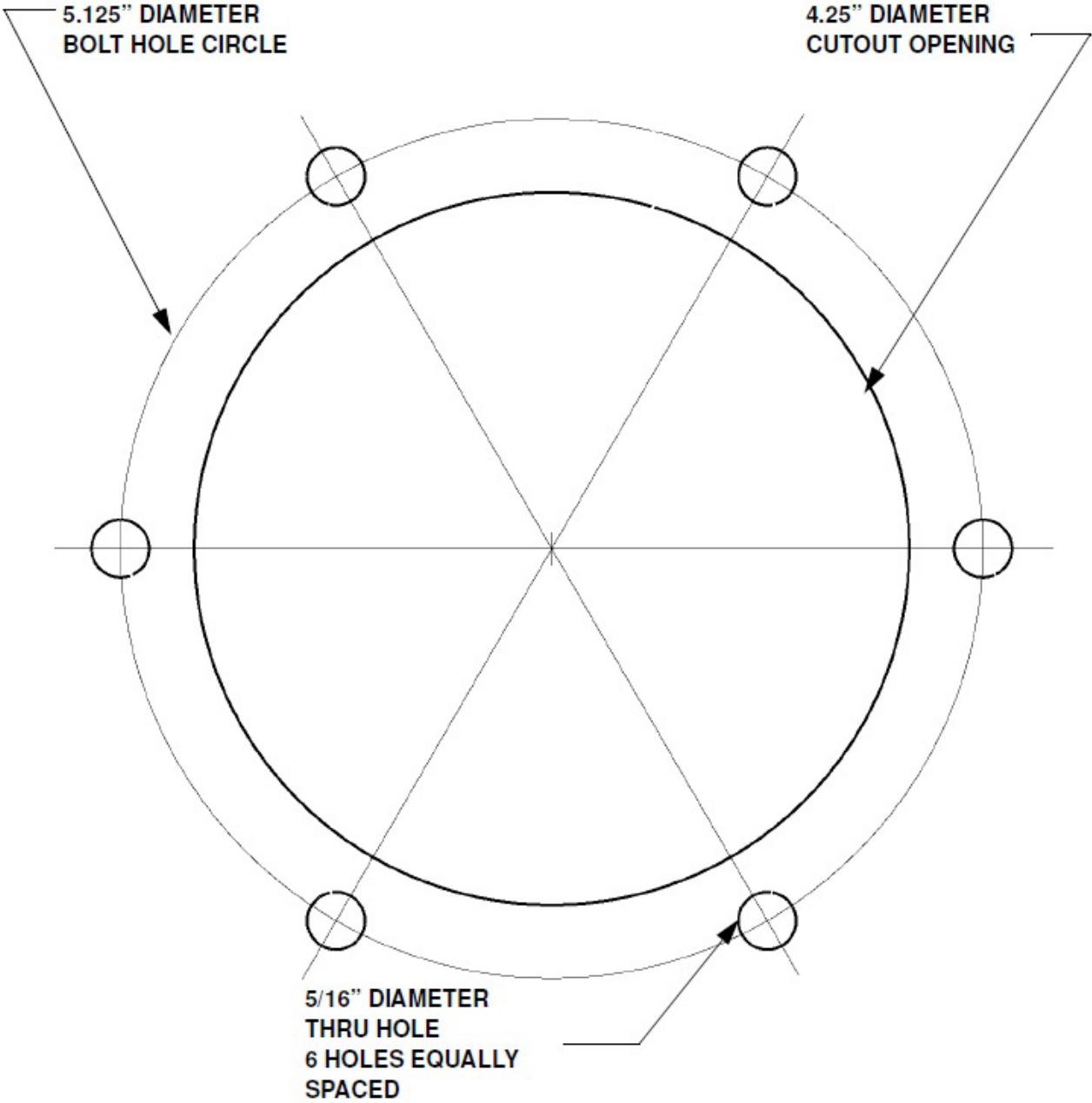

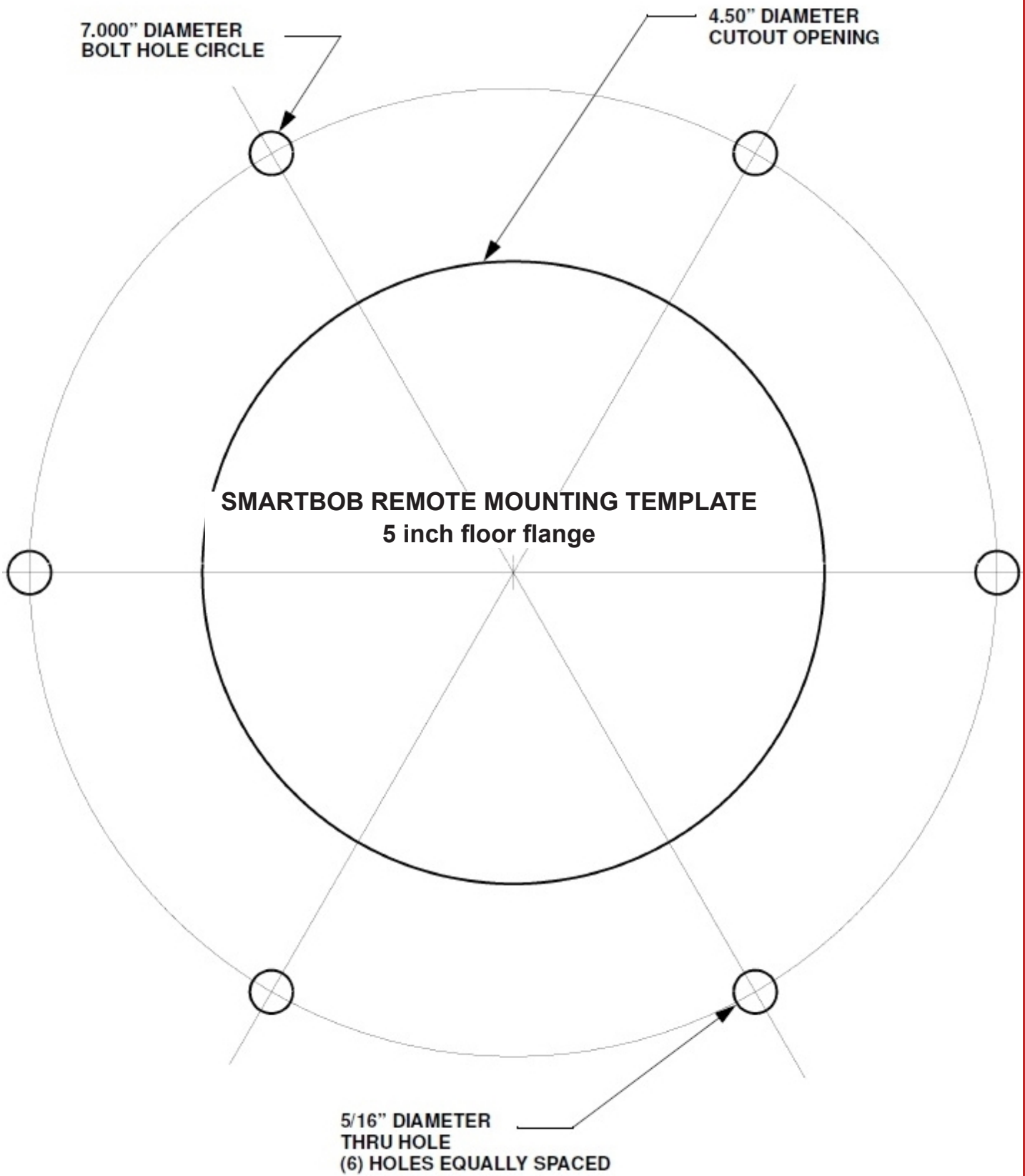

# SureDrop Cable Release System

## Assembly Instructions

Assemble the SureDrop cable release system in the order as shown in the figure below.

- > Ball Stop
- > Round Crimp
- > Ball Stop
- > Round Crimp
- > Cap
- > Ball Stop
- > Oval Crimp
- > Thimble
- > Cable

After all items are located as shown, compress the crimps in place. When compressing the crimps, be careful not to over tighten. Over tightening could cut and damage the cable.

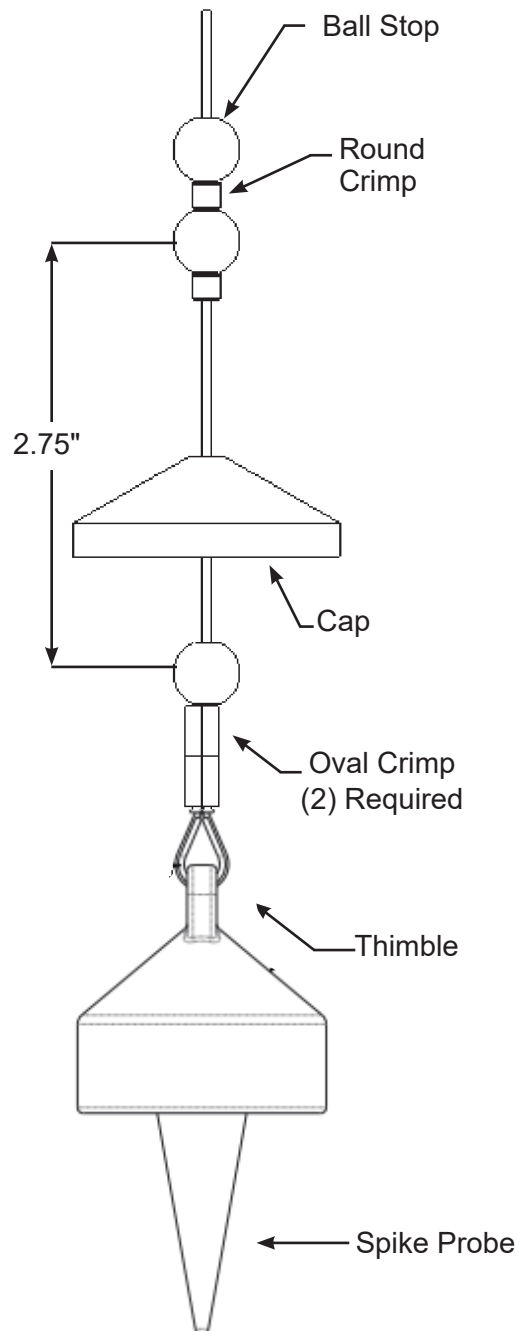

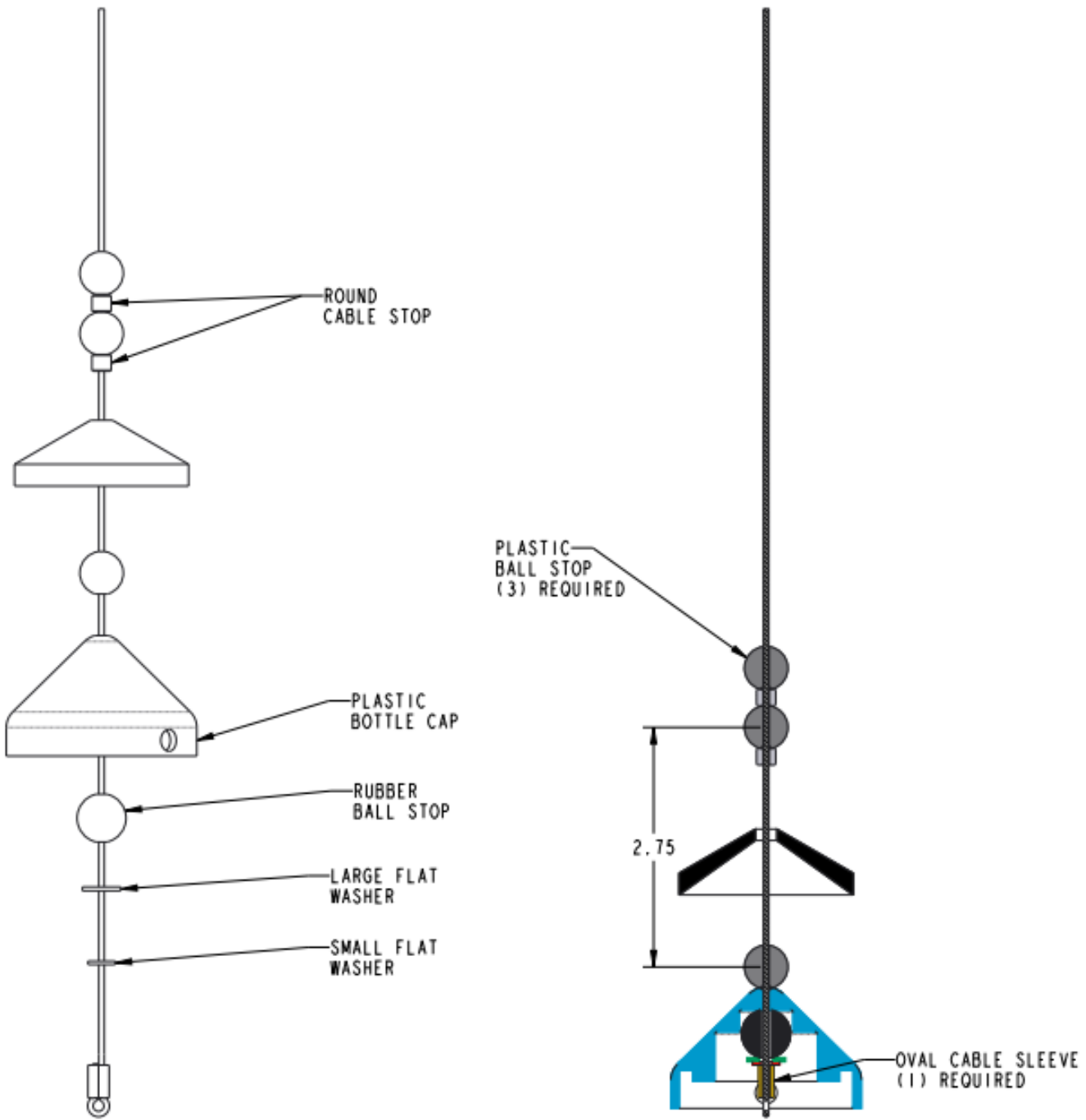

SUREDROP CABLE RELEASE SYSTEM  
USED WITH ALL DIGESTIBLE  
PLASTIC BOTTLES